

PROPOSAL PENAWARAN PEMBUATAN
SYSTEM KOMPUTERISASI
INDUSTRI/MANUFACTURE



Oleh Mardi Waluyo
Software Engineer

Proposal Penawaran Pembuatan
Software / Program Aplikasi Kebutuhan
INDUSTRI / MANUFACTURE

Seiring dengan kemajuan teknologi dibidang informasi, adalah merupakan pilihan yang bijaksana bila suatu usaha ditunjang dengan sarana dan prasarana informasi yang cepat tepat dan akurat, karena hal ini akan membantu dalam banyak hal.

Sehubungan dengan hal tsb kami dari sebuah Team profesional yang sudah berpengalaman dibidang pembuatan Software System ingin menawarkan suatu **System Komputerisasi untuk kebutuhan Industri / Manufacture yang ter-Integrasi** yang terdiri dari beberapa modul yang terintegrasi al,

- Accounting
- Indenting & Purchasing & Storing
- Marketing
- Bill Of Materials (BOM)
- PPIC (Production Planning & Inventory Control)
- Absensi & Payroll

dengan tujuan,

- Meningkatkan kualitas dan disiplin kerja.
- Meningkatkan kualitas pelayanan kepada Customer.
- Terdukungnya Management dengan informasi-informasi yang cepat, tepat dan akurat.
- Terkelolanya data dan informasi dengan baik.

System ini bekerja dibawah Windows Operating System dan dapat dioperasikan oleh lebih dari satu orang secara bersamaan (multi user) dengan operasional yang mudah dan dilengkapi dengan fasilitas-fasilitas bantuan pencarian data.

Dilengkapi pula dengan system keamanan yang optimal untuk menjamin aplikasi dioperasikan oleh user yang berhak/berwenang sehingga mengurangi terjadinya miss operation (salah operasional).

System ini kami rancang se-sistematis mungkin dan mudah dioperasikan dengan tujuan untuk mempermudah pekerjaan yang ditunjang dengan informasi-informasi yang cepat, tepat dan akurat.

Bila diperlukan kami akan mengadakan perubahan-perubahan/modifikasi sesuai dengan kebutuhan..

Lembar-lembar berikut adalah Spesfikasi yang kami tawarkan.

Malang, 7 April 2016

Mardi Waluyo
Software Engineer
081359297246

Sekilas tentang System yang kami tawarkan.

Adalah sebuah system komputerisasi yang sangat diperlukan untuk mengelola usaha di bidang **Industri / Manufacture** untuk memenuhi kebutuhan informasi management secara umum.

Aplikasi ini mendukung proses integrasi aplikasi mulai dari **Front** sampai **Backend**.

System ini bekerja dibawah Windows Operating System dan dapat dioperasikan oleh lebih dari satu orang secara bersamaan (multi user) dengan operasional yang mudah dan dilengkapi dengan fasilitas-fasilitas bantuan pencarian data.

Untuk Generate Laporan-laporan kami menggunakan **Crystal Report** (report Generator) yang handal dan dinamis yang bisa di Convert/Export ke format lain (excel, pdf, text dll).

System ini kami rancang se-sistematis mungkin dan mudah dioperasikan dengan tujuan untuk mempermudah pekerjaan yang ditunjang dengan informasi-informasi yang cepat, tepat dan akurat.

Pada aplikasi ini data ter-Update secara **Real time** tanpa harus menunggu proses akhir dan sudah mendukung proses **integasi** mulai dari Front sampai Backend.

Proteksi/Keamanan

Untuk menjaga keamanan, dalam Operasionalnya kami menggunakan Password dan batasan-batasan operasional yang di klasifikasikan sbb,

1. **Operator** dengan hak operasionalnya adalah sbb,
 - Entry Data
 - Cetak Laporan Transaksi
2. **Supervisor** dengan hak operasionalnya sbb
 - Entry Data
 - Cetak Laporan
 - Setting Tabel-tabel
 - Cetak semua Laporan.
3. **Administrator**, Berhak mengoperasikan semua modul yang ada.

Spesifikasi Hardware

- | | |
|---------------------|---|
| - Processor | Pentium IV setara atau lebih |
| - Memory | Minimum 512 untuk Client,
Minimum 1 Gb untuk Server. |
| - Hard Disk | Minimum 40 Gb. |
| - Network Interface | Ethernet Integrated 10/100 mbps |
| - Printer | Dot Matrik untuk Kasir. |

Berikut ini adalah Modul-modul yang kami tawarkan.

Marketing

Modul-modul

- **Entry**
 - o **Tabel** yang terdiri dari
 - Customer (Input Data Customer secara Detail.
 - Harga Product (Barang Jadi)
 - o **Order**
Input Data Order dari Customer
Input Data Order untuk Stock
 - o Delivery Order (DO)
Input Data **Pengiriman Barang Jadi**.
Mencetak **Faktur Penjualan**.
 - o Invoice.
Input Data Invoice berdasarkan Delivery Order.
Mencetak **Form Invoice**.
- **Laporan**
 - o Laporan Order
 - o Status Order (agar bisa diketahui berapa yang sudah dikirim dan berapa yang belum)
 - o Delivery Order (DO).
 - o Invoice
 - o Dll.

Bill Of Materials (BOM)

Modul-modul

- **Entry**
 - o Entry & Print BOM (Bill Of Materials)
Meng-Input Data kebutuhan **bahan baku, bahan pembantu dan biaya produksi** untuk menghasilkan nilai **HPP** tiap-tiap Product.
 - o Approve BOM (Bill Of Materials)
Approve / Menyetujui / Men-Sahkan Data kebutuhan material untuk tiap-tiap Product setelah di Check secara seksama oleh yang berhak.
- **Laporan**
 - o Daftar Item Product.

Production Planning & Inventory Control (PPIC)

Modul-modul

- **Entry SPK**
Membuat SPK (Surat Pertintah Kerja) berdasarkan Order dari Marketing dan BOM.
- **Mencetak Daftar Kebutuhan Material yang terkait dengan SPK.**
- **Entry Indent**
Membuat Indent (Pesanan barang) untuk memenuhi kebutuhan SPK bila Stock di Gudang kosong atau tidak mencukupi.
- **Mencetak dan Mendistribusikan SPK ke Produksi.**
- **Entry data hasil kerja.**
Input Data Hasil Kerja agar bisa diketahui status dari SPK tsb.
- **Laporan SPK**
 - o Status SPK (sudah sejauh mana hasilnya).
 - o Status Pemakaian Material (menguraian berapa estimasi pemakaian, berapa realisasi pemakaian, dan berapa variant nya).

Inventory Control

Modul-modul

- File-file Tabel yang terdiri dari
 - o Master Barang
 - o Stock Awal
 - o Supplier

Indenting(PesananBarang)

Pemesanan barang untuk kebutuhan **Produksi** (mengacu pada SPK) atau kebutuhan **Non-Produksi**

- o Entry Indent & Cetak From Indent
Input Data Pesanan Barang dan sekaligus mencetak Form Pesanan.
- o Approve Indent
Persetujuan Pesanan Barang (oleh yang berhak).
- o Laporan-laporan
 - Daftar Indent
 - Status Indent agar bisa diketahui,
 - sudah di-Approve atau belum
 - sudah dibuatkan PO atau belum
 - barang sudah datang atau belum

Purchase Order (Order Pembelian Barang)

Pembuatan Purchase Order (PO) berdasarkan ***Indent***.

- Entry PO & Cetak From PO
Input Data Purchase Order dan sekaligus mencetak Form PO..
- Approve PO
Persetujuan PO (oleh yang berhak).
- Laporan-laporan
 - Daftar PO
 - Status PO agar bisa diketahui,
 - sudah di-Approve atau belum
 - barang sudah datang atau belum

Gudang/Store.

- Entry Transaksi
 - Penerimaan Pembelian Barang (dari Supplier).
 - Pemakaian Barang (untuk Produksi & Non Produksi).
 - Retur Pembelian Barang (ke Supplier
 - Retur Pemakaian Barang.
 - Penerimaan Hasil Produksi (dari Pabrik)
 - Pengiriman Hasil Produksi.
 - Adjustment
- Laporan-laporan
 - Transaksi
 - Pembelian Barang.
 - Pemakaian Barang.
 - Retur Pembelian
 - Retur Penjualan
 - Penerimaan Hasil Produksi
 - Pengiriman Hasil Produksi
 - Adjustment
 - Stock Barang
 - Kartu Stock
 - Stock Opname
 - Minimum Stock

Accounting / General Ledger

Modul-modul

1. Setting

1. Chart Of Account

Setting No. Account/Perkiraan

2. Jenis Jurnal.

Setting Jenis/Macam Jurnal yang akan digunakan agar Jurnal terkelompok sesuai dengan jenisnya misal,

- Jurnal Bank
- Jurnal Kas
- Jurnal Umum
- Jurnal Hutang/Piutang

3. Otomatisasi .

Setting Otomasi No. Account

2. Transaksi/Jurnal yang terdiri dari

a. Jurnal Kas / Bank

Entry/memasukan Data transaksi yang berhubungan dengan Kas atau Bank.
Mencetak Form Cash/Bank Voucher.

b. Jurnal Umum

Entry/memasukan Data transaksi yang tidak berhubungan dengan Kas dan Bank.
(misal, Adjustment dll)

c. Hutang / Piutang

Entry/memasukan Data transaksi yang bersangkutan dengan terjadinya Hutang/Piutang.

3. Laporan-laporan

1. Jurnal.

Mencetak laporan Jurnal transaksi yang terjadi pada periode tertentu yang terdiri dari

- **Kas / Bank**
- **Jurnal Umum**
- **Hutang / Piutang**

2. Posisi Kas & Bank (Cash & Bank Statement)

Mencetak Posisi / keadaan *Kas* dan *Bank* pada periode tertentu agar dapat diketahui keberadaan saldonya.

3. General Ledger (Transaksi per No. Account)

Mencetak laporan Transaksi yang pada No. Account tertentu dan pada periode tertentu.

4. Transaksi per Sub Account

Mencetak laporan Transaksi yang pada Sub Account tertentu dan pada periode tertentu.

5. Transaksi per Sub Ledger

Mencetak laporan Transaksi yang pada Sub Ledger tertentu dan pada periode tertentu.

6. Register Saldo Hutang / Piutang

Mencetak laporan Hutang atau Piutang agar dapat diketahui posisi atau statusnya (lunas atau belum dan kapan jatuh temponya).

7. Neraca Saldo

8. Neraca Lajur

9. Laba Rugi

10. Neraca

4. Proses

1. Tutup Buku

- Akhir Bulan

Hal ini dilakukan bila transaksi-transaksi dan laporan-laporan pada bulan yang dimaksud sudah dianggap selesai, selanjutnya transaksi pada bulan tsb *tidak dapat dirubah/edit* lagi dan akan terbentuk *saldo awal* pada account Neraca untuk bulan berikutnya.

- Akhir Tahun

Hal ini dilakukan bila transaksi-transaksi dan laporan-laporan sampai dengan akhir tahun dianggap selesai, selanjutnya transaksi pada tahun tsb *tidak dapat dirubah/edit* lagi dan akan terbentuk *saldo awal* pada account Neraca untuk tahun & bulan berikutnya.

2. Pembatalan Tutup Buku.

Hal ini dilakukan bila masih ada koreksi transaksi pada bulan yang sudah ditutup, dan dapat dikerjakan hanya oleh orang-orang yang *berhak*. Setelah dilakukan koreksi, kemudian harus ditutup kembali.

Catatan,

- Bila diperlukan kami bersedia mengadakan perubahan-perubahan seperlunya sesuai kebutuhan Perusahaan.

SYSTEM FLOW

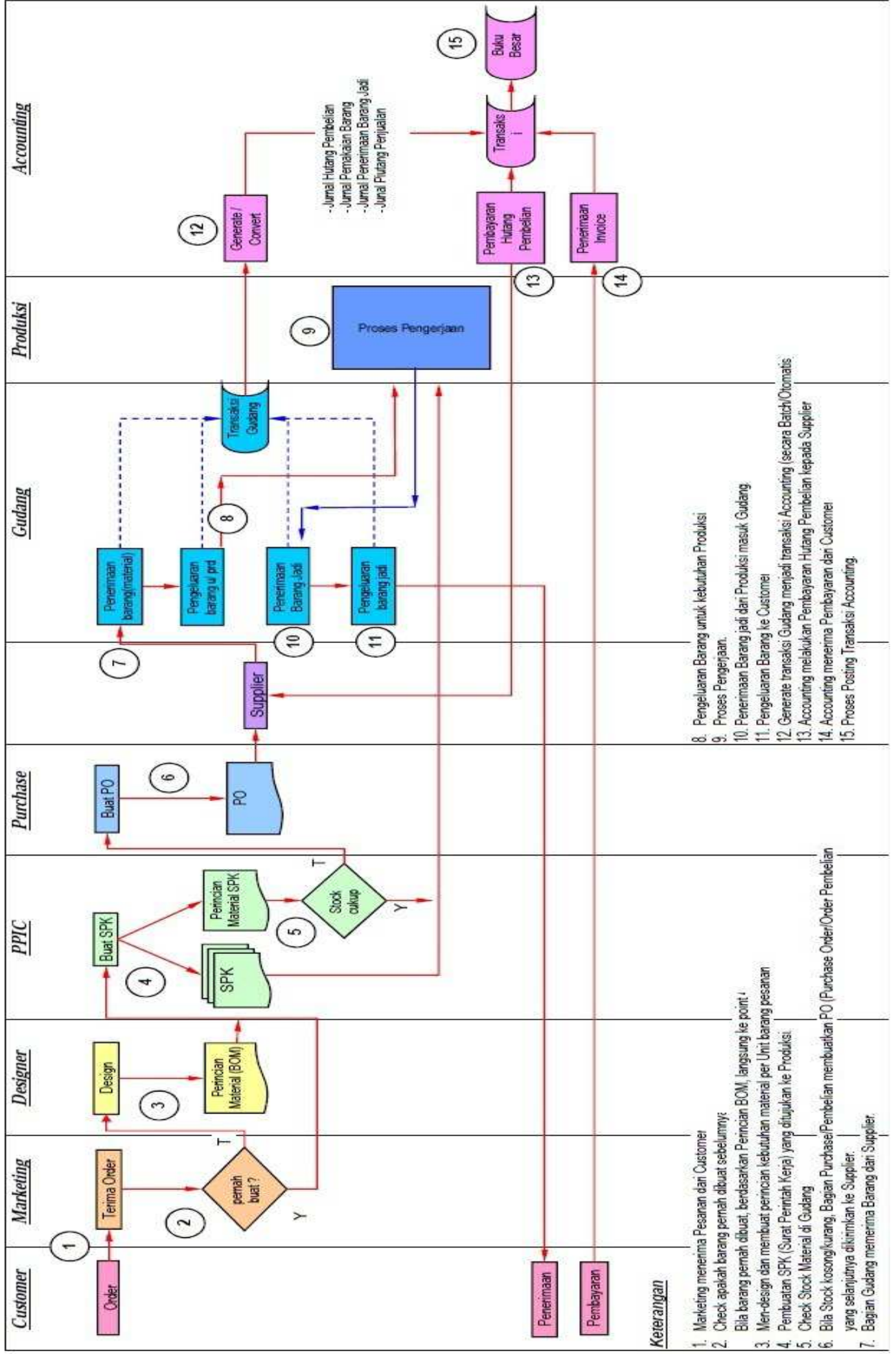

Contoh Screen & Report Layout

Main Menu / Menu Utama

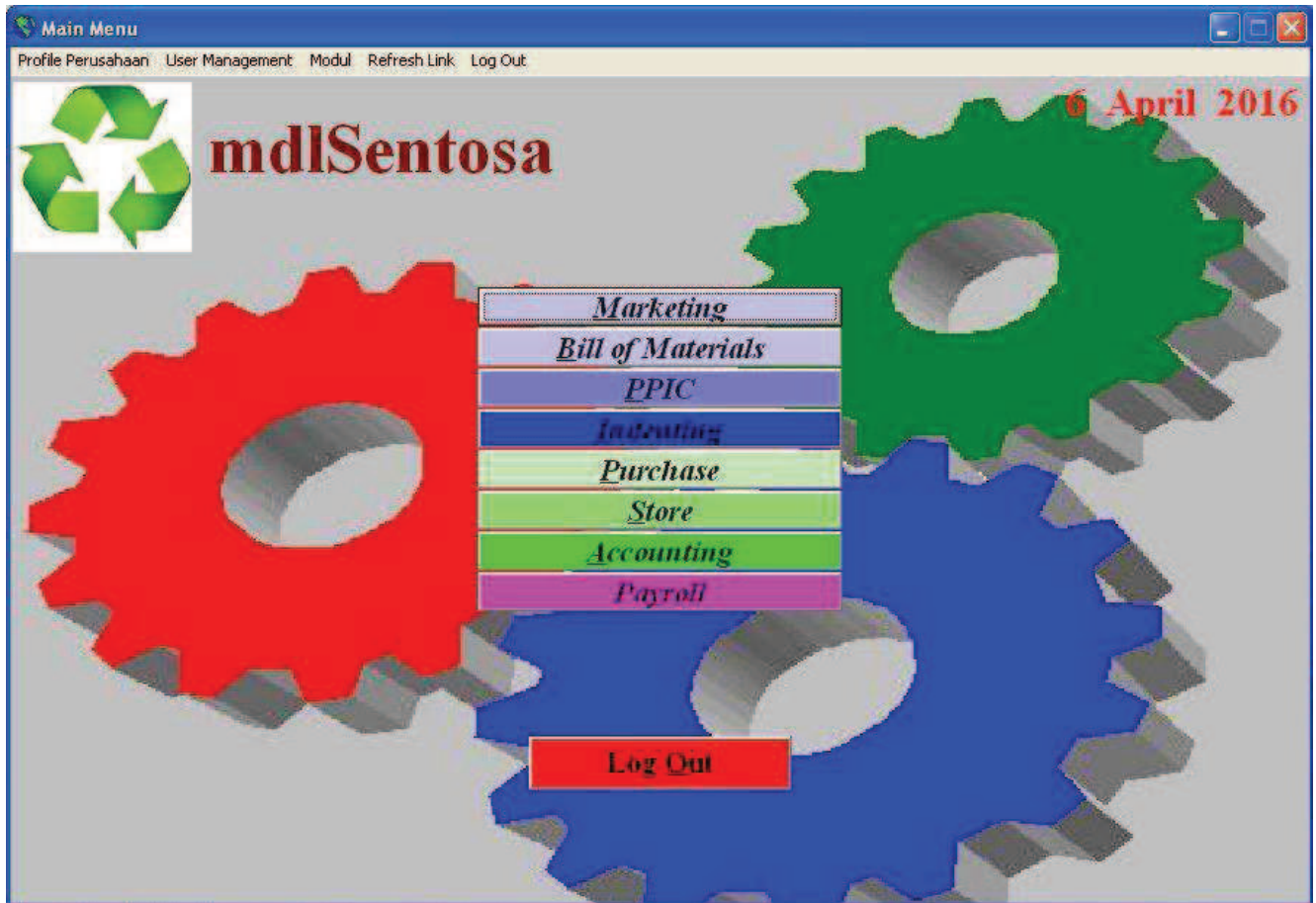

Sub Menu Marketing

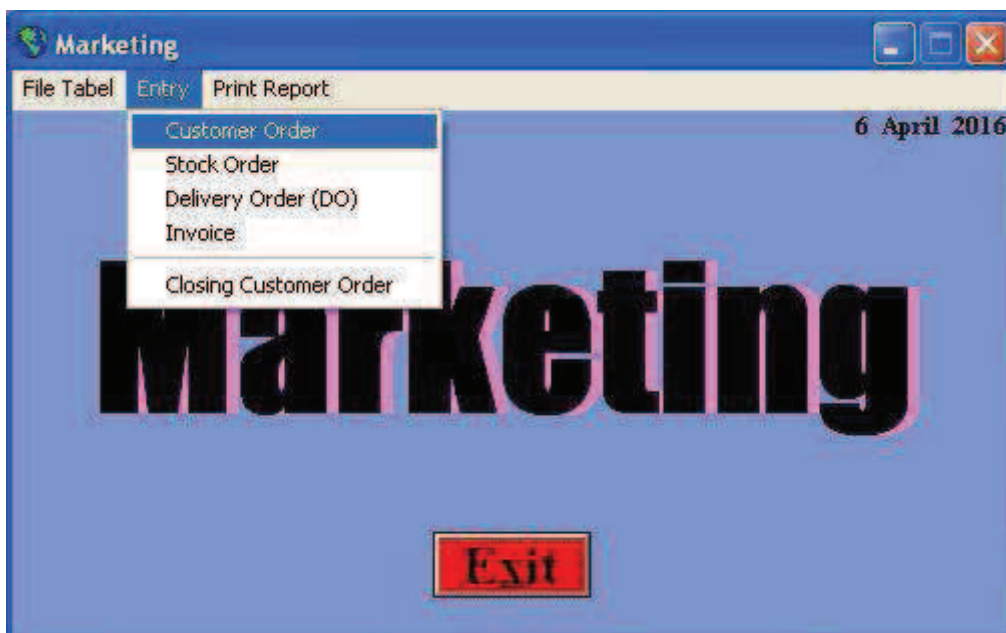

Sub Menu BOM



Sub Menu PPIC



Sub Menu Indenting



Sub Menu Purchase

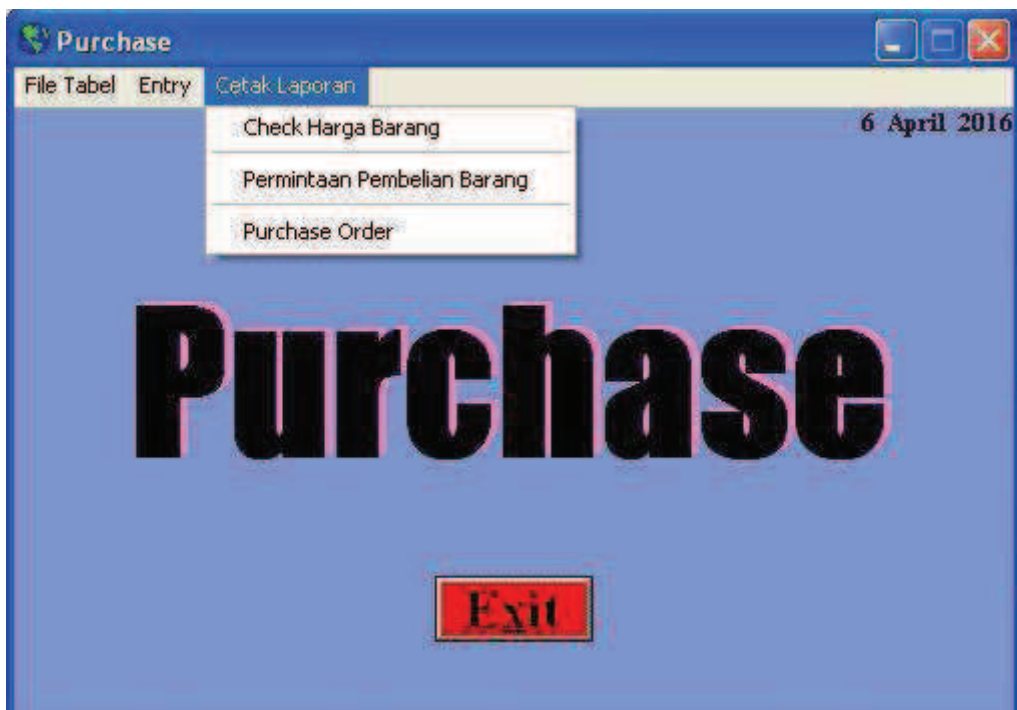

Sub Menu Store (Gudang)

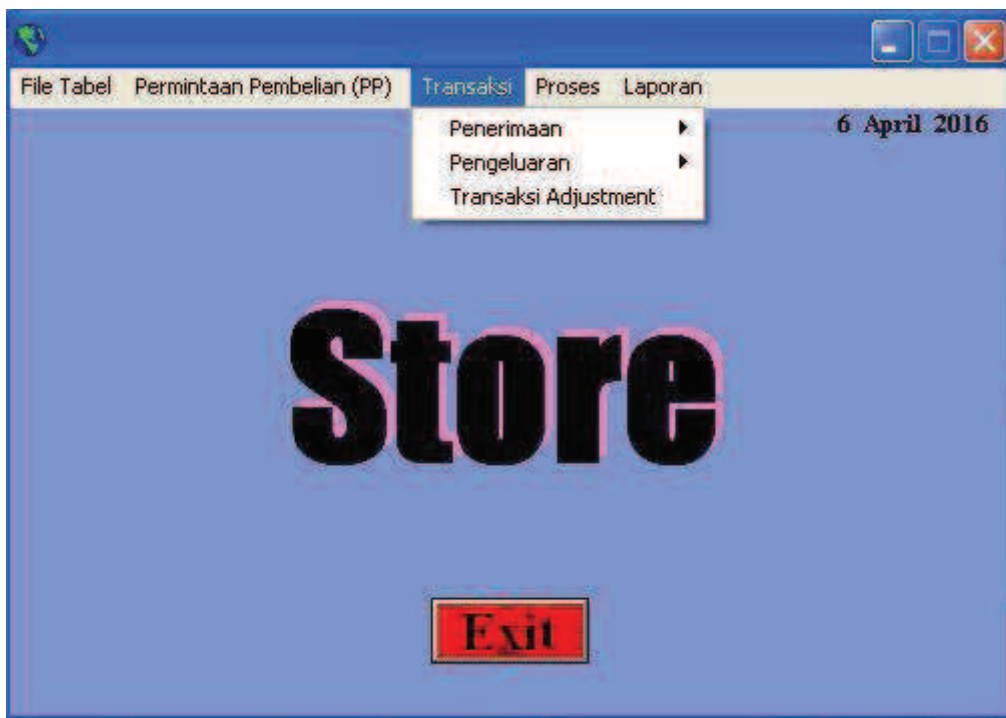

Sub Menu Accounting

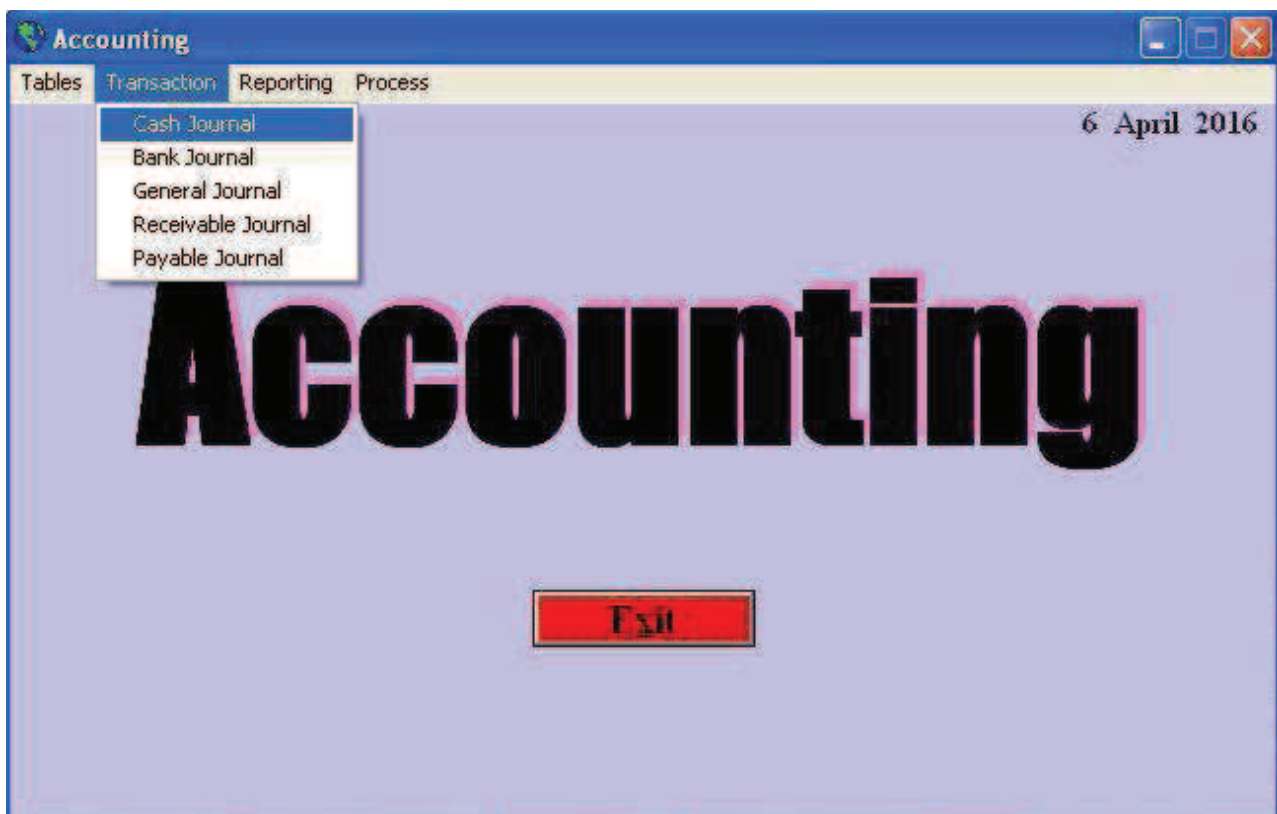

Sub Menu Payroll

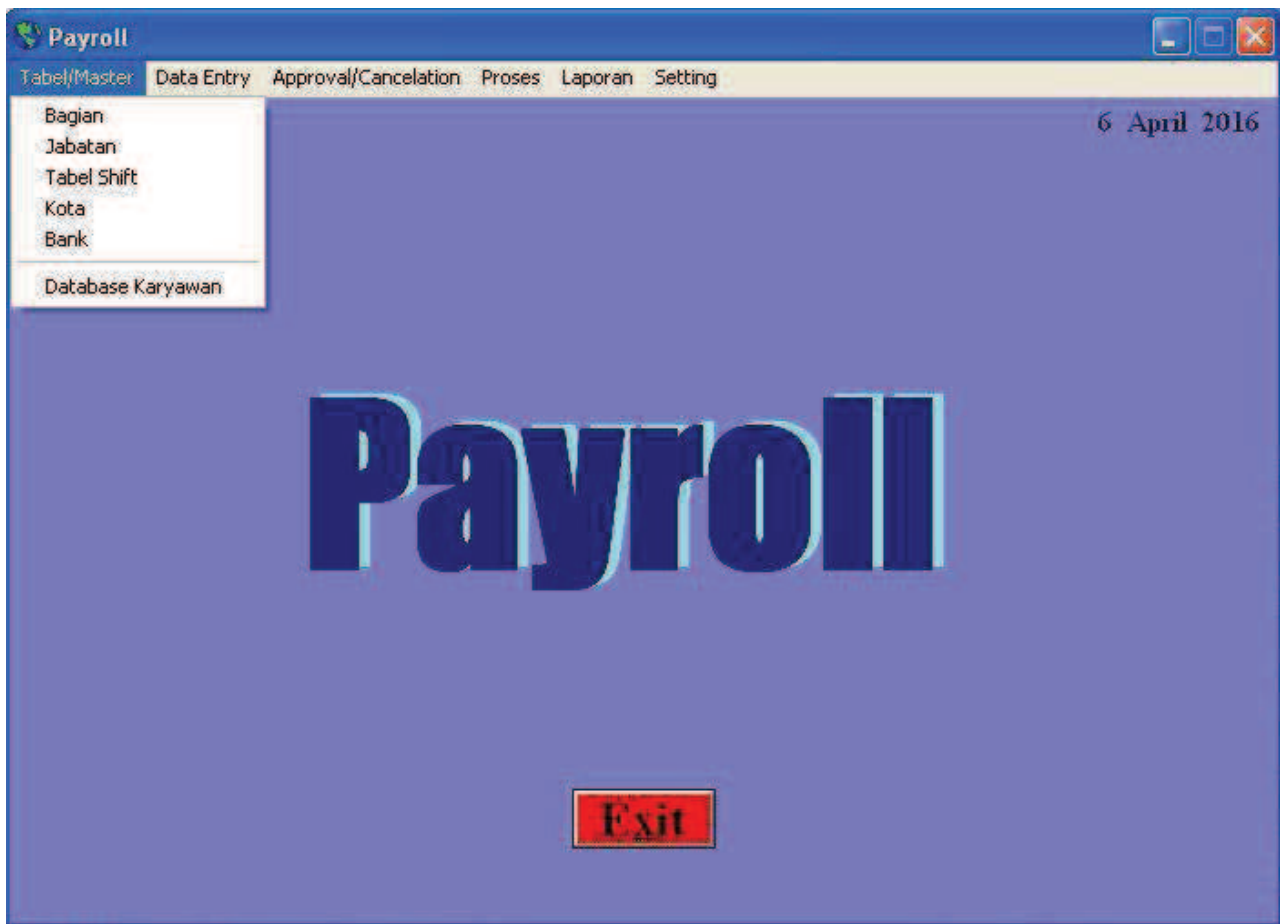

Marketing

Entry Customer Order

Customer Order

Order No. / /

Date

Customer

Reference Est. Ship Date

Currency Terms of sale

Detail

No.	Product Code	Product Name	Specification	Quantity	UM	Price	Total	Discount (%)	Discount Amount	Tax (%)	Tax Amount	Total Amount
1	A.01.10001	Jl - Tree Only		10	Pcs	59.35	593.50	0.00	0.00	0.00	0.00	593.50
2	A.01.10007	Jl - L (DT)		10	Pcs	93.30	933.00	0.00	0.00	0.00	0.00	933.00
3	A.01.10019	Java Mini - S		200	Pcs	15.40	3,080.00	0.00	0.00	0.00	0.00	3,080.00
Total							4,606.50	0.00	0.00	0.00	0.00	4,606.50

Bila di-Click tombol *Print* maka akan tampil *Customer Order Form* sbb,



mdISentosa
Pakis Permata Asri A-16 Malang
Telp. 081 359 297246

Customer Order

CO. No. : CO/2013/00001
Date : 03/Jan/2013
Order No. : No. Order Customer

Est. Ship Date : 31/01/2013
Term : Ex - Work xxx

A&E Cage CO.,LLC
4551 E. Route 130 South Burlington
NJ
08016
USA

Phone : 11 22 33
Attention : fffdsfdfsfsdf

No.	Item Code	Description	Specification	UM	Qty	Unit Price	Discount (%)	Tax (%)	Total
1	A.01.10001	Jl -Tree Only		Pcs	10	59.35	0.00	0.00	593.50
2	A.01.10007	Jl - L (DT)		Pcs	10	93.30	0.00	0.00	933.00
3	A.01.10019	Java Mini - S		Pcs	200	15.40	0.00	0.00	3,080.00
Total									4,606.50

Entry Stock Order

Stock Order

Order No. / /

Date

Detail

No.	Product Code	Product Name	Specification	Quantity	UM
▶ 1	A.01.10001	Jl - Tree Only		5	Pcs
2	A.01.10007	Jl - L (DT)		5	Pcs

Total

Save
 Clear
 Delete
 Print
 Un-approve
 Exit

Bila di-Click tombol *Print* maka akan tampil *Stock Order Form* sbb,

	mdlSentosa Pakis Permata Asri A-16 Malang Telp. 081 359 297246				
	Stock Order				
Kepada : Yth, Kepala P P I C		Order . No. : OS/2013/00001 Date : 02/01/2013			
Harap dikerjakan pembuatan barang-barang / produk pesanan sebagai berikut,					
No.	Item Code	Description	Specification	UM	Qty
1	A.01.10001	Jl - Tree Only		Pcs	5
2	A.01.10007	Jl - L (DT)		Pcs	5
Total					10

Entry Delivery Order

Delivery Order

Month **Januari** 2013

DO No. **DO / 2013 / 01 / 00001**

Date **25/Jan/2013**

Order No. **CO/2013/00001** Customer **AE Cage CO.,LLC**

Detail

No.	Item CO	Product Code	Description	Specification	UM	Quantity	Unit Price	Value
1	1	A.01.10001	JI - Tree Only		Pes	1	223,687.26	223,687.26
2	2	A.01.10007	JI - L (DT)		Pes	2	404,540.05	809,080.10
3	3	A.01.10019	Java Mini - S		Pes	200	63,738.93	12,747,786.00

Total **203** **13,780,553.36**

Save Clear Delete Print Exit

Bila di-Click tombol *Print* maka akan tampil *Delivery Order Form* sbb,

mdlSentosa Page 1 of 1

DELIVERY ORDER

Nomor : DO/2013/01/00001
Tanggal : 25/01/2013

Kepada
Yth :
Manager Gudang

No. OC :
Customer :

Dengan ini mohon dikeluarkan barang-barang sbb,

No	Kode	Nama Barang	Spesifikasi	Jumlah	Satuan
1	A.01.10001	JI - Tree Only		1	Pcs
2	A.01.10007	JI - L (DT)		2	Pcs
3	A.01.10019	Java Mini - S		200	Pcs

Dibuat oleh, Mengetahui Disetujui oleh,

(.....) (.....) (.....)

Entry Invoice

INVOICE

Invoice No. INV / 2016 / 00001

Date: 12/Jan/2016 Order No. CO/2013/00001 Currency: US\$
 DO No. DO-2013-01-00001 Customer: A&E Cage CO,LLC

Packing No. Pack 99999 Gross Wt (kg) 5000 kg Total Item (pcs) 50
 Container: Continer xxxxx Net Wt (kg) 5000 kgs E T A: 12/Jan/2016
 Seal No. Seal No. xxxx Volume (cbm) 1000 cbm Ship Date: 12/Jan/2016 Via: I don't know

Detail

No.	Item CO	Product Code	Description	Specification	UM	Quantity	Unit Price	Value
1	1	A.01.10001	JI - Tree Only		Pcs	1	59.35	59.35
2	2	A.01.10007	JI - L (DT)		Pcs	2	93.30	186.60
3	3	A.01.10019	Java Mini - S		Pcs	200	15.40	3,080.00
Total 203 3,325.95								

Save Clear Delete Print Exit

Bila di-Click tombol *Print* maka akan tampil *Invoice Form* sbb,

	mdSentosa Pakis Permata Asri A-16 Malang Telp. 081 359 297246	Invoice No. : INV/2016/00001 Invoice Date : 12/01/2016 Page : Page 1 of 1				
A&E Cage CO.,LLC 4551 E. Route 130 South Burlington NJ 08016 USA						
Phone 11 22 33 Attention fffdsfdfsfsdf						
Order No.	Ship Date	Ship Via	E T A	Terms of sale	Currency	
No. Order Customer	12/01/2016	I don't know	12/Jan/2016	Ex - Work xxx	US\$	
Container No	Seal No	Net Wt (kg)	Gross Wt (kg)	Volume (cbm)	Total Item (pcs)	
Continer xxxxx	Seal No. xxxxx	5000 kgs	5000 kg	1000 cbm	50	
No.	Manufacture Code	Description	Specification	Qty	Unit Price	Total
1	A.01.10001	JI - Tree Only		1	59.35	59
2	A.01.10007	JI - L (DT)		2	93.30	187
3	A.01.10019	Java Mini - S		200	15.40	3,080
Total						3,326

Laporan Finished Good (Barang Jadi)

Code		Description	Size	UM	Curr Stock	Allocated			Consumed			Free Stock
						Date	To	Qty	Date	By	Qty	
A.01.10001		Jl - Tree Only		Pcs	0							0
						02/01/2013	SPK/2013/00001	1	25/01/2013	D.O/2013/01/00001	1	0
A.01.10002		Jl - S	S	Pcs	0							0
A.01.10003		Jl - S (DT)		Pcs	0							0
A.01.10004		Jl - M		Pcs	0							0
A.01.10005		Jl - M (DT)		Pcs	0							0
A.01.10006		Jl - L		Pcs	0							0
A.01.10007		Jl - L (DT)		Pcs	0							0
						02/01/2013	SPK/2013/00001	2	25/01/2013	D.O/2013/01/00001	2	0
A.01.10008		Jl - L + Carving		Pcs	0							0
A.01.10009		Jl - L + Carving (DT)		Pcs	0							0
A.01.10010		Jl - Double Tree		Pcs	0							0
A.01.10011		Jl - Double Tree (DT)		Pcs	0							0
A.01.10012		Jl - Double + Carving		Pcs	0							0
A.01.10013		Jl - Double + Carving (DT)		Pcs	0							0
A.01.10014		Jl - Deluxe Tree		Pcs	0							0
A.01.10015		Jl - S - incl carton box		Pcs	0							0
A.01.10016		Jl - M - incl carton box		Pcs	0							0
A.01.10017		Jl - L - incl carton box		Pcs	0							0
A.01.10018		Java Mini - XS		Pcs	0							0
A.01.10019		Java Mini - S		Pcs	0							-43
						02/01/2013	SPK/2013/00001	200	25/01/2013	D.O/2013/01/00001	200	0
						03/01/2013	SPK/2013/00002	43				0
A.01.10020		Java Mini - M		Pcs	0							0
A.01.10021		Java Mini - L		Pcs	0							0
A.01.10022		Java Mini - XL		Pcs	0							0

List of Customer Order

Order		Customer	Srl	Product			Qty	Price	Total
Number	Date			Code	Name & Specification	UM			
CO/2013/00001	03/01/2013	A0001 [A&E Cage CO.,LLC]	1	A.01.10001	Jl - Tree Only	Pcs	10	59.35	593.50
			2	A.01.10007	Jl - L (DT)	Pcs	10	93.30	933.00
			3	A.01.10019	Java Mini - S	Pcs	200	15.40	3,080.00
							Total		4,806.50
CO/2013/00002	04/01/2013	B0003 [Bidia]	1	A.01.10001	Jl - Tree Only	Pcs	10	59.35	593.50
			2	A.01.10007	Jl - L (DT)	Pcs	10	93.30	933.00
			3	A.01.10019	Java Mini - S	Pcs	200	15.40	3,080.00
							Total		4,806.50
CO/2015/00001	10/01/2015	P0003 [PET GOODIES NL]	1	A.01.10001	Jl - Tree Only	Pcs	1,000	52.80	52,800.00
			2	A.01.10002	Jl - S	Pcs	1,000	63.30	63,300.00
							Total		116,100.00
OS/2013/00001	02/01/2013		1	A.01.10001	Jl - Tree Only	Pcs	5	0.00	0.00
			2	A.01.10007	Jl - L (DT)	Pcs	5	0.00	0.00
							Total		0.00
							Grand Total		125,313.00

Laporan Customer Order Status

mdSentosa Halaman 1

Customer Order Status

Period from 01/01/2013 to 04/07/2016

Order		Customer	Srl	Product			Qty	Delivered		Balance	Closed	
Number	Date			Code	Name & Specification	UM	Order	Date	Qty			
CO 2013/00001 03/01/2013		A0001 [A&E Cage CO.,LLC]										
			1	A.01.10001	Jl - Tree Only	Pcs	10	12/01/2016	1	9		
			2	A.01.10007	Jl - L (DT)	Pcs	10	12/01/2016	2	8		
			3	A.01.10019	Java Mini - S	Pcs	200	12/01/2016	200	0		
							Total					
									220	203	17	
CO 2013/00002 04/01/2013		B0003 [Birdie]										
			1	A.01.10001	Jl - Tree Only	Pcs	10					
			2	A.01.10007	Jl - L (DT)	Pcs	10					
			3	A.01.10019	Java Mini - S	Pcs	200					
							Total					
									220			
CO 2013/00001 10/01/2015		P0003 [PET GOODIES NL]										
			1	A.01.10001	Jl - Tree Only	Pcs	1,000					
			2	A.01.10002	Jl - S	Pcs	1,000					
							Total					
									2,000			

Delivery Order Report

mdSentosa Halaman 1

Delivery Order Report

Period 01/01/2013 to 06/04/2016

D O No.	Customer	Item	Product Code	Description & Specification	Quantity	Price	Value	Invoice				
								Curr	Price	Value		
DO 2013/01/00001 25/01/2013	A&E Cage Co.,LLC											
		1	A.01.10001	Jl - Tree Only	1 Pcs	223,687.26	223,687.26	US \$	59.35	59.35		
		2	A.01.10007	Jl - L (DT)	2 Pcs	404,540.05	809,080.10	US \$	93.30	186.60		
		3	A.01.10019	Java Mini - S	200 Pcs	63,738.93	12,747,786.00	US \$	15.40	3,080.00		
							Total					
								13,780,553.36			3,325.95	
							Grand Total		13,780,553.36		3,325.95	

Invoice Report

mdSentosa

Invoice Report
 Period: 01/01/2013 to 06/04/2016

Halaman 1

Invoice No.	Date	Customer	Order No. D O No.	Item	Product Code	Description & Specification	Quantity	Curr	Price	Value
INVJ2016/00001	01/12/2016	A&E Cage C o.,LLC	CO/2013/00001 DO/2013/01/00001							
				1	A.01.10001	Jl - Tree Only	1 Pcs	US \$	59.35	59.35
				2	A.01.10007	Jl - L (DT)	2 Pcs	US \$	93.30	186.60
				3	A.01.10019	Java Mini - S	200 Pcs	US \$	15.40	3,080.00
							Total	US \$		3,325.95
							Grand Total	US \$		3,325.95

Bill of Materials

Entry BOM

Bill of Materials

Item Code:

Description: Size: Length: cm(s) Height: cm(s)

Specification: Weight: kg(s) Width: cm(s)

Per Tanggal:

Bahan Baku

No.	Kode Barang	Nama Barang	Spesifikasi	UM	Harga	Harga Standard	Jumlah	Total
1	D.01.10002	Tree L.		Pcs	147,000.00	147,000.00	1.0000	147,000.00
Total								147,000.00



Bahan Pembantu

No.	Kode Barang	Nama Barang	Spesifikasi	UM	Harga	Harga Standard	Jumlah	Total
1	B.10.10051	Reng KN-M3x25x2mm.		Pcs	700.00	700.00	3.0000	2,100.00
2	B.10.10022	Eye Bolt NK #8		Pcs	197.00	197.00	4.0000	788.00
3	B.10.10009	Bolt KN M3x0.6x1.25		Pcs	435.00	435.00	3.0000	1,305.00
4	E04.40007	Len. Putih Rajswali	1 pack = 800 GRM	GRM	8,750.00	20.00	50.0000	1,000.00
5	B.10.10045	SS AS204-10mm.DrnmP	1 lonjor jd 50 bag (1 lonjor di bag	Pcs	2,788.00	2,900.00	2.0000	5,800.00
6	B.10.10046	SS Pipe201-1/2"Dr1.27mm	1 lonjor jadi 85 pcs (1 lonjor di b	Pcs	598.00	700.00	2.0000	1,400.00
7	B.10.10036	Nams E25-M3x2.57mm		Pcs	652.00	652.00	2.0000	1,304.00
8	E04.40003	Epoxy for Production		KG	128,000.00	128,000.00	0.0100	1,280.00
9	E01.10003	Desiccant 1000 gram		Pcs	35,065.00	35,065.00	0.2400	8,415.60
10	B.10.10028	Hanger Bolt NK.M3x3.0x1.25		PCS	800.00	800.00	2.0000	1,600.00
11	E01.10003	Desiccant 1000 gram		Pcs	35,065.00	35,065.00	0.2400	8,415.60
12	E09.90008	Amplas Rol-#520		CM	550,000.00	200.00	5.0000	1,000.00
Total Cost (Rp.)								223,687.26
Total								34,468.20

Manufacturing Cost

No.	Description	Amount (Rp.)
1	RM - Cutting	3,921.74
2	Karcher	9,534.96
3	Kita Dry	23,212.87
4	Carpentry - Drilling	223.39
5	Carpentry - Planer	229.13
6	Carpentry - Planer	3,112.55
7	Packing	1,984.42
Total		42,219.06

Bila di-Click tombol *Print* maka akan tampil 2 buah *Form BOM* sbb,

Bill Of Material

Product Code : A.01.10001
Product Name : II - Tree Only
Specification :
Size :
Weigth : 0.00 cm(s)
Length : 0.00 cm(s)
Width : 0.00 cm(s)
Height : 0.00 cm(s)
Total Cost : Rp. 223,687.26
Date Created : 01/01/2013



 Dibuat

Diperiksa

Disetujui

Disetujui

{.....}

{.....}

{.....}

{.....}

Product Code : A.01.10001
 Product Name : II - Tree Only
 Spesifikasi :
 Tanggal : 01/01/2013

Kebutuhan Bahan Baku

No.	Kode	Nama & Spesifikasi	Jumlah	Harga	Harga Standard	Total
1	D.01.10002	Tree L	1.00 Pcs	147,000.00	147,000.00	147,000.00
Total						147,000.00

Kebutuhan Bahan Pembantu

No.	Kode	Nama & Spesifikasi	Jumlah	Harga	Harga Standard	Total
1	B.10.10051	Reng KN-M8x30x3mm	3.00 Pcs	700.00	700.00	2,100.00
2	B.10.10022	EyeBolt NK #8	4.00 Pcs	197.00	197.00	788.00
3	B.10.10009	Bolt KN M8x60x1.25	3.00 Pcs	455.00	455.00	1,365.00
4	E.04.40007	Lem Putih Rajawali / 1 pack = 800 GRM	50.00 GR	8,750.00	20.00	1,000.00
5	B.10.10045	S5 AS304-10mmDx6mP / 1lonjor jd 50 btg (1 lonjor di bagi 12cm)	2.00 Pcs	2,788.00	2,900.00	5,800.00
6	B.10.10046	S5 Pipa201-1/2"Dx1.27mm / 1 lonjor jadi 85 pcs (1 lonjor di bagi 7cm)	2.00 Pcs	598.00	700.00	1,400.00
7	B.10.10036	Nanas E25-M8x25Tmm	2.00 Pcs	652.00	652.00	1,304.00
8	E.04.40003	Epoxy for Production	0.01 KG	128,000.00	128,000.00	1,280.00
9	E.01.10003	Desiccant 1000 gram	0.24 Pcs	35,065.00	35,065.00	8,415.60
10	B.10.10028	Hanger Bolt NK M8x50x1.25	2.00 PCS	800.00	800.00	1,600.00
11	E.01.10003	Desiccant 1000 gram	0.24 Pcs	35,065.00	35,065.00	8,415.60
12	E.09.90008	Amplas Rol-#320	5.00 CM	550,000.00	200.00	1,000.00
Total						34,468.20

Manufacturing Cost

No.	Description	Total
1	RM - Cutting	3,921.74
2	Karcher	9,534.96
3	Klin Dry	23,212.87
4	Carpentry - Drilling	223.39
5	Carpentry - Planner	229.13
6	Carpentry - Planner	3,112.55
7	Packing	1,984.42
Total		42,219.06
Grand Total		223,687.26

Daftar Product

Daftar Produk								Halaman 1	
No.	Kode Produk	Nama Produk / Spesifikasi	Tanggal Berlaku	Nilai				Di Approve	
				Bhn Baku	Bhn Pembantu	FOH	Total	Oleh	Tanggal
1	A.01.10001	JI - Tree Only	01/01/2013	147,000.00	34,468.20	42,219.06	223,687.26	DWI	13/09/2013
			26/05/2014	147,000.00	32,763.00	42,219.06	221,982.06	DWI	07/06/2014
			26/08/2014	147,000.00	32,763.00	61,537.67	241,900.67		
			07/10/2014	161,700.00	32,778.00	61,537.67	256,015.67	DWI	11/10/2014
2	A.01.10002	JI - S	01/01/2013	131,904.20	69,972.50	65,326.78	267,203.48	DWI	29/10/2013
			26/05/2014	141,409.00	76,169.50	65,326.78	282,905.28		
			07/10/2014	148,252.42	75,908.25	65,326.78	289,487.45		07/11/2014
3	A.01.10003	JI - S (DT)	01/01/2013	131,904.20	74,162.98	68,126.23	274,193.41	DWI	31/10/2013
			26/05/2014	141,404.20	75,424.65	68,126.23	284,955.08		07/06/2014
			21/06/2014	141,404.20	75,576.65	68,126.23	285,107.08	DWI	21/06/2014
			07/10/2014	148,324.42	75,290.40	68,126.23	291,741.05	DWI	07/11/2014
4	A.01.10004	JI - M	01/01/2013	193,504.20	73,234.55	81,350.94	348,089.69	DWI	31/10/2013
			26/05/2014	204,504.20	78,973.00	81,350.94	364,828.14		
			07/10/2014	215,004.20	78,973.00	81,350.94	375,328.14	DWI	11/10/2014
			07/11/2014	215,004.20	78,726.75	81,350.94	375,081.89	DWI	07/11/2014
5	A.01.10005	JI - M (DT)	01/01/2013	193,504.20	78,710.89	88,579.08	360,794.17	DWI	31/10/2013
			19/05/2014	205,104.20	86,381.35	88,579.08	380,064.63	DWI	07/06/2014
			21/06/2014	205,181.00	86,421.35	88,579.08	380,181.43	DWI	21/06/2014
			07/10/2014	215,681.00	86,135.10	88,579.08	390,395.18	DWI	07/11/2014
6	A.01.10006	JI - L	01/01/2013	237,904.20	90,448.64	75,302.36	403,655.20	DWI	31/10/2013
			26/05/2014	252,004.20	94,764.05	75,302.36	422,070.61		
			07/10/2014	267,004.20	94,764.05	75,302.36	437,070.61	DWI	11/10/2014
			07/11/2014	267,004.20	94,402.80	75,302.36	436,709.36	DWI	07/11/2014
7	A.01.10007	JI - L (DT)	01/01/2013	237,904.20	89,640.30	76,995.55	404,540.05	DWI	31/10/2013
			26/05/2014	250,804.20	98,010.71	76,995.55	425,810.46	DWI	07/06/2014
			07/10/2014	265,804.20	97,649.46	76,995.55	440,449.21	DWI	07/11/2014

PPIC

Entry SPK (Surat Perintah Kerja)

Surat Perintah Kerja

Nomor:

Tanggal:

Tgl. Mulai: Tgl. Selesai:

Menunjuk Order

Nomor: Customer:

Tanggal: Referensi:

Detail

No.	Item Order	Kode Product	Nama Product	Spesifikasi	Sat	Qty. Order	Qty Stock	Sudah Ter-Alokasi	Free Stock	Qty Di-Alokasikan	Qty SPK	Keterangan
1	1	A.01.10001	Jl - Tree Only		Pcs	10	1	0	1	1	9	
2	2	A.01.10007	Jl - L (DT)		Pcs	10	2	0	2	2	8	
3	3	A.01.10019	Java Mini - S		Pcs	200	243	0	243	200	0	
*												

Save
Clear
Delete
Print
Un-approve
Exit

Bila di-Click tombol *Print* maka akan tampil 3 buah *Form SPK* sbb,

mdlSentosa Pakis Permata Asri A-16 Malang Telp. 081 359 297246	SURAT PERINTAH KERJA (SPK)	Nomor : SPK/2013/00001 Tgl Terbit : 02/01/2013 No. Order : CO/2013/00001 Tgl mulai : 02/01/2013 Tgl Selesai : 02/01/2013																												
Kepada : Yth, Kepala Produksi																														
Harap dikerjakan pembuatan barang-barang / produk pesanan A&E Cage CO.,LLC sebagai berikut,																														
<table border="1" style="width: 100%; border-collapse: collapse;"> <thead> <tr> <th>No.</th> <th>Kode Product</th> <th>Nama Product</th> <th>Spesifikasi</th> <th>Satuan</th> <th>Jumlah Barang</th> <th>Keterangan</th> </tr> </thead> <tbody> <tr> <td>1</td> <td>A.01.10001</td> <td>Jl - Tree Only</td> <td></td> <td>Pcs</td> <td>9</td> <td></td> </tr> <tr> <td>2</td> <td>A.01.10007</td> <td>Jl - L (DT)</td> <td></td> <td>Pcs</td> <td>8</td> <td></td> </tr> <tr> <td>3</td> <td>A.01.10019</td> <td>Java Mini - S</td> <td></td> <td>Pcs</td> <td>0</td> <td></td> </tr> </tbody> </table>	No.	Kode Product	Nama Product	Spesifikasi	Satuan	Jumlah Barang	Keterangan	1	A.01.10001	Jl - Tree Only		Pcs	9		2	A.01.10007	Jl - L (DT)		Pcs	8		3	A.01.10019	Java Mini - S		Pcs	0			
No.	Kode Product	Nama Product	Spesifikasi	Satuan	Jumlah Barang	Keterangan																								
1	A.01.10001	Jl - Tree Only		Pcs	9																									
2	A.01.10007	Jl - L (DT)		Pcs	8																									
3	A.01.10019	Java Mini - S		Pcs	0																									

Kebutuhan Material

Halaman 1

No. SPK : SPK/2013/00001
 Tgl Terbit : 02/01/2013
 No. Order : CO/2013/00001

Tgl mulai : 02/01/2013
 Tgl Selesai : 02/01/2013

No.	Kode	Nama Barang	Spesifikasi	Jumlah
Bahan Baku				
1	B.06.60031	Timber Mixing 2Tx10L(200-250)P		0.0960 Cbm
2	B.06.60036	Timber Mixing 2Tx6.5L(90-250)P		0.0000 Cbm
3	B.06.60045	Plywood 15mm		2.6400 Lbr
4	B.06.60047	Plywood 9mm		0.0000 Lbr
5	B.09.90006	Katalis Norox MEKP 9H		0.1280 KG
6	B.09.90009	Resin F61344		1.9200 KG
7	B.09.90010	Silica Sand		5.9200 Kg
8	D.01.10002	Tree L		17.0000 Pcs
9	D.01.10007	Mini S		0.0000 Pcs
Bahan Pembantu				
10	B.08.80009	Box-Mini S-273x59x423mm		0.0000 Pcs
11	B.08.80011	Box Wrap J1B-1205x800x89mm		8.0000 Pcs
12	B.08.80016	Kertas Minyak		16.0000 Lbr
13	B.08.80019	Plastic Roda-12Lx25Pcm	1 Pack = 100 Pcs	40.0000 PCS
14	B.10.10008	Bolt KN M8x40x1.25		0.0000 Pcs
15	B.10.10009	Bolt KN M8x60x1.25		51.0000 Pcs
16	B.10.10021	Eye Bolt NK #6		0.0000 Pcs
17	B.10.10022	Eye Bolt NK #8		68.0000 Pcs
18	B.10.10027	Hanger Bolt	NK M6x50x1mm	0.0000 Pcs
19	B.10.10032	Nails F20	1 Box = 5000 Pcs	360.0000 Pcs
20	B.10.10033	Nails F25	1 Box = 5000 Pcs	160.0000 Pcs
21	B.10.10035	Nanas E11-M8x13Tmm		16.0000 Pcs
22	B.10.10036	Nanas E25-M8x25Tmm		42.0000 Pcs
23	B.10.10039	Nanas E47-M6x10Tmm		0.0000 Pcs
24	B.10.10045	SS AS304-10mmDx6mP	1 lonjor jd 50 btg (1 lonjor di bagi 12cm)	34.0000 Pcs
25	B.10.10046	SS Pipa201-1/2"Dx1.2Tmm	1 lonjor jadi 85 pcs (1 lonjor di bagi 7cm)	34.0000 Pcs
26	B.10.10051	Reng KN-M8x30x3mm		27.0000 Pcs
27	B.10.10052	Roda Casters SG50		40.0000 Pcs
28	B.10.10053	Roda Karet		0.0000 Pcs

Kebutuhan Material per Product

Halaman 1

No. SPK : SPK/2013/00001
 Tgl Terbit : 02/01/2013
 No. Order : CO/2013/00001

Tgl mulai : 02/01/2013
 Tgl Selesai : 02/01/2013

P R O D U C T				M A T E R I A L			
No.	Kode	Nama & Spesifikasi	Jumlah	No.	Kode	Nama & Spesifikasi	Jumlah
1	A.01.10001	Jl.-Tree Only	9 Pcs	Bahan Baku			
				1	D.01.10002	Tree L	9.0000 Pcs
				Bahan Pembantu			
				2	B.10.10051	Reng KN-M8x30x3mm	27.0000 Pcs
				3	B.10.10022	Eye Bolt NK #6	36.0000 Pcs
				4	B.10.10009	Bolt KN M8x60x1.25	27.0000 Pcs
				5	E.04.40007	Lem Putih Raja wali 1 pack = 800 GRM	450.0000 GR
				6	B.10.10045	SS AS304-10mmDx6mP 1 lonjor jd 50 btg (1 lonjor di	18.0000 Pcs
				7	B.10.10046	SS Pipa201-1/2"Dx1.2Tmm 1 lonjor jadi 85 pcs (1	18.0000 Pcs
				8	B.10.10036	Nanas E25-M8x25Tmm	18.0000 Pcs
				9	E.04.40003	Epoxy for Production	0.0900 KG
				10	E.01.10003	Desiccant 1000 gram	2.1600 Pcs
				11	B.10.10028	Hanger Bolt NK M6x50x1.25	18.0000 PC
				12	E.09.90008	Amplas Rol-#320	45.0000 CM

Entry Hasil Produksi

Hasil Produksi

No. S.P.K.

Tanggal

Tgl. Mulai Tgl. Selesai

Menyajikan Order

Nomor Customer

Tanggal Referensi

Detail *A.01.10001*

No.	Item Order	Kode Product	Nama Product	Spesifikasi	Sat	Jumlah Order	Jumlah Selesai	Sisa	Tanggal	Jumlah Selesai
1	1	A.01.10001	Jl. Tree Only		Pcs	9	0	9	*	
2	2	A.01.10007	Jl - L (DT)		Pcs	8	0	8		
3	3	A.01.10019	Java Mini - S		Pcs	0	0	0		

Clear Exit

Entry Berita Acara Penyerahan Barang (hasil Produksi)

Berita Acara Penyerahan Barang Jadi (BAP)

Nomor / / /

Tanggal

No. SPK

Detail

No.	Item Spk	Kode Barang	Nama Barang	Spesifikasi	Sat	Jumlah	Remarks

Clear Delete Print Exit

Daftar SPK

Daftar Surat Perintah Kerja (SPK)										Halaman 1	
Tanggal 01/01/2013 to 04/07/2016											
S. P. K.		Srl	P r o d u c t			Jumlah	Tanggal		Order		
Nomor	Tanggal		Code	Name & Specification	Sat.		Mulai	Selesai	Nomor	Tanggal	
SPK.2013/00001	02/01/2013						02/01/2013	02/01/2013	CO.2013/00001	03/Jan/13	
		1	A.01.10001	JI - Tree Only	Pes	9					
		2	A.01.10007	JI - L (DT)	Pes	8					
		3	A.01.10019	Java Mini - S	Pes	0					
SPK.2013/00002	03/01/2013						03/01/2013	03/01/2013	CO.2013/00002	04/Jan/13	
		1	A.01.10001	JI - Tree Only	Pes	10					
		2	A.01.10007	JI - L (DT)	Pes	10					
		3	A.01.10019	Java Mini - S	Pes	157					
SPK.2013/00003	03/01/2013						03/01/2013	03/01/2013	OS.2013/00001	02/Jan/13	
		1	A.01.10001	JI - Tree Only	Pes	5					
		2	A.01.10007	JI - L (DT)	Pes	5					
SPK.2015/00001	01/06/2015						02/06/2015	25/06/2015	CO.2015/00001	10/Jan/15	
		1	A.01.10001	JI - Tree Only	Pes	1,000					
		2	A.01.10002	JI - S	Pes	1,000					

Laporan Status SPK

Status Surat Perintah Kerja (SPK)										Halaman 1		
Per Tanggal 07/04/2016												
S. P. K.		Srl	P r o d u c t			Jumlah	Selesai		Tanggal		Order	
Nomor	Tanggal		Code	Name & Specification	Sat.		Tanggal	Jumlah	Mulai	Selesai	Nomor	Tanggal
SPK.2013/00001	02/01/2013							02/01/2013	02/01/2013	CO.2013/00001	03/Jan/13	
		1	A.01.10001	JI - Tree Only	Pes	9						
		2	A.01.10007	JI - L (DT)	Pes	8						
		3	A.01.10019	Java Mini - S	Pes	0						
SPK.2013/00002	03/01/2013							03/01/2013	03/01/2013	CO.2013/00002	04/Jan/13	
		1	A.01.10001	JI - Tree Only	Pes	10						
		2	A.01.10007	JI - L (DT)	Pes	10						
		3	A.01.10019	Java Mini - S	Pes	157						
SPK.2013/00003	03/01/2013							03/01/2013	03/01/2013	OS.2013/00001	02/Jan/13	
		1	A.01.10001	JI - Tree Only	Pes	5						
		2	A.01.10007	JI - L (DT)	Pes	5						
SPK.2015/00001	01/06/2015							02/06/2015	25/06/2015	CO.2015/00001	10/Jan/15	
		1	A.01.10001	JI - Tree Only	Pes	1,000						
		2	A.01.10002	JI - S	Pes	1,000						

Indenting

Entry PB (Permintaan Barang)

Permintaan Barang
(PB)

Nomor / / /

Tanggal No. SPK

Ber SPK Non SPK

Detail

No.	Item Spk	Kode Barang	Nama Barang	Spesifikasi	Sat. Pakai	Jumlah kebutuhan	Remarks
1	1	B.06.60034	Timber Mixing 2Tx20L(150-190)P		CBM	10.00	
2	2	B.06.60045	Plywood 15mm		Lbr	250.00	
3	3	B.09.90006	Katalis Norox MEKP 9H		KG	16.00	
4	4	B.09.90010	Silica Sand		Kg	740.00	
5	5	D.01.10002	Tree L		Pcs	1,000.00	
6	6	D.01.10004	Tree S		Pcs	1,000.00	
7	7	B.09.90023	Resin XPR 0904 F		KG	240.00	
8	8	B.08.80011	Box Wrap J1B-1205x900x89mm		Pcs	1,000.00	
9	9	B.08.80016	Kertas Minyak		Lbr	2,000.00	
10	10	B.10.10009	Bolt KN M8x60x1.25		Pcs	5,000.00	
11	11	B.10.10022	EyeBolt NK #8		Pcs	8,000.00	
12	12	B.10.10032	Nails F20	1 Box = 5000 Pcs	Pcs	15,000.00	
13	13	B.10.10033	Nails F25	1 Box = 5000 Pcs	Pcs	40,000.00	
14	14	B.10.10035	Nanas E11-M8x13Tmm		Pcs	2,000.00	
15	15	B.10.10036	Nanas E25-M8x25Tmm		Pcs	4,000.00	
16	16	B.10.10045	SS AS304-10mmDx6mP	1lonjor jd 50 bty (1 lonjor di l	Pcs	2,000.00	
17	17	B.10.10046	SS Pipa201-1/2"Dx1.2Tmm	1 lonjor jadi 85 pcs (1 lonjor	Pcs	2,000.00	
18	18	B.10.10062	Screw JP M8x3/4"		Pcs	16,000.00	
19	19	B.10.10068	Staples Gun ISI-1008J	1 Pack = 5000 Pcs	Pcs	40,000.00	
20	20	B.11.11014	DLL Sanding Hardener ICM 21B		Ltr	76.00	

Bila di-Click tombol *Print* maka akan tampil *Form PB* sbb,

mdISentosa		PERMINTAAN BARANG		Nomor : PB/2015/06/00001		
Kepada				Tanggal : 03/06/2015		
Yth : Manager Gudang				SPK No. : SPK/2015/00001		
Dengan ini mohon disiapkan kebutuhan barang-barang sbh,						
No	Kode	Nama Barang	Spesifikasi	Jumlah	Satuan	Keterangan
1	B.06.60034	Timber Mixing 2Tx20L(150-190)P		10.00	CBM	
2	B.06.60045	Plywood 15mm		250.00	Lbr	
3	B.09.90006	Katalis Norox MEKP 9H		16.00	KG	
4	B.09.90010	Silica Sand		740.00	Kg	
5	D.01.10002	Tree L		1,000.00	Pcs	
6	D.01.10004	Tree S		1,000.00	Pcs	
7	B.09.90023	Resin XPR 0904 F		240.00	KG	
8	B.08.80011	Box Wrap J1 B-1205x300x89mm		1,000.00	Pcs	
9	B.08.80016	Kertas Minyak		2,000.00	Lbr	
10	B.10.10009	Bolt KN M8x60x1.25		5,000.00	Pcs	
11	B.10.10022	Eye Bolt NK #6		8,000.00	Pcs	
12	B.10.10032	Nails F20	1 Box = 5000 Pcs	15,000.00	Pcs	
13	B.10.10033	Nails F25	1 Box = 5000 Pcs	40,000.00	Pcs	
14	B.10.10035	Nanas E11-M8x13Tmm		2,000.00	Pcs	
15	B.10.10036	Nanas E25-M8x25Tmm		4,000.00	Pcs	
16	B.10.10045	SS A8304-10mm Dx6mP	1 lonjor jd 50 btg (1 lonjor di bagi 12cm)	2,000.00	Pcs	
17	B.10.10046	SS Pipa 201-1.2"D x 1.2Tmm	1 lonjor jadi 85 pcs (1 lonjor di bagi 7cm)	2,000.00	Pcs	
18	B.10.10062	Screw JP M8x3/4"		16,000.00	Pcs	
19	B.10.10068	Staples Gun ISI-1008J	1 Pack = 5000 Pcs	40,000.00	Pcs	
20	B.11.11014	PU Sanding Hardener ICN 21B		76.00	Ltr	
21	B.11.11015	PU Sanding Sealer ICN 700A		96.00	Ltr	
22	B.11.11016	PU Top Coat IGF 660 A 70% Matt		109.00	Ltr	
23	B.11.11018	PU Thinner R1280		200.00	Ltr	
24	B.11.11028	Thinner Cuci AC-37		30.00	Ltr	
25	B.11.11030	Wood Filler Mahony WS6113384		100.00	KG	
26	E.01.10003	Desiccant 1000 gram		680.00	Pcs	
27	E.04.40003	Epoxy for Production		20.00	KG	
28	E.04.40007	Lem Putih Raja wali	1 pack = 800 GRM	135,000.00	GRM	
29	E.09.90005	Amplas Rol-#100		5,000.00	CM	
30	E.09.90008	Amplas Rol-#320		10,000.00	CM	
31	B.10.10028	Hanger Bolt NK M8x50 x 1.25		4,000.00	PCS	
32	B.10.10077	Reng KN M8 x 30 x 1.5		7,000.00	PCS	
33	B.10.10079	Roda Castors Without Brake	H 55 Dia 40	4,000.00	PCS	
34	E.04.40005	Epoxy for Production		20.00	KG	

Laporan Permintaan Barang (PB)

Permintaan Barang		Barang			No. SPK / Bagian	Remarks		
Nomor	Tanggal	Srl	Kode	Nama / Spesifikasi			Jumlah	
PB/2013/01/00001	05/01/2013	1	E.03.30052	Saklar / Seri isi 3 Panasonic	10.00	SET	BUL / BUILDING	Testing
PB/2013/01/00002	10/01/2013	1	E.03.30052	Saklar / Seri isi 3 Panasonic	50.00	SET	BUL / BUILDING	Testig ke 2
PB/2015/06/00001	03/06/2015	1	B.06.60034	Timber Mixing 2T x 20L (150-190)P	10.00	CB	SPK/2015/00001	
		2	B.06.60045	Plywood 15mm	250.00	Lbr		
		3	B.09.90006	Katalis Norox MEKP 9H	16.00	KG		
		4	B.09.90010	Silica Sand	740.00	KG		
		5	D.01.10002	Tree L	1,000.00	Pcs		
		6	D.01.10004	Tree S	1,000.00	Pcs		
		7	B.09.90023	Resin XPR 0904F	240.00	KG		
		8	B.08.80011	Box Wrap JB-1205x900x89mm	1,000.00	Pcs		
		9	B.08.80016	Kertas Minyak	2,000.00	Lbr		
		10	B.10.10009	Bolt KN M8x60x1.25	5,000.00	Pcs		
		11	B.10.10022	Eye Bolt NK #8	8,000.00	Pcs		
		12	B.10.10032	Nails F20 / 1 Box = 5000 Pcs	15,000.00	Pcs		
		13	B.10.10033	Nails F25 / 1 Box = 5000 Pcs	40,000.00	Pcs		
		14	B.10.10035	Nanas E 11-M8x13Tmm	2,000.00	Pcs		
		15	B.10.10036	Nanas E 25-M8x25Tmm	4,000.00	Pcs		
		16	B.10.10045	SS AS 304-10m mDx6mP / lonjor jd 50 kg (1 lo	2,000.00	Pcs		
		17	B.10.10046	SS Pipa 201-1/2"Dx1.2Tmm / 1 lonjor jadi 85 pcs (2,000.00	Pcs		
		18	B.10.10062	Screw JP M8x3/4"	16,000.00	Pcs		
		19	B.10.10068	Staples Gun ISI-1008J / 1 Pack = 5000 Pcs	40,000.00	Pcs		
		20	B.11.11014	PU Sanding Hardener ICN 21B	76.00	Ltr		
		21	B.11.11015	PU Sanding Sealer ICN 700A	96.00	Ltr		
		22	B.11.11016	PU Top Coat IGF 660A 70% Matt	109.00	Ltr		
		23	B.11.11018	PU Thinner R1280	200.00	Ltr		
		24	B.11.11028	Thinner Cuci AC-37	30.00	Ltr		
		25	B.11.11030	Wood Filler Mahony WS6113384	100.00	KG		
		26	E.01.10003	Desiccant 1000 gram	680.00	Pcs		
		27	E.04.40003	Epoxy for Production	20.00	KG		
		28	E.04.40007	Lem Putih Rajawali / 1 pack = 800 GRM	35,000.00	GR		
		29	E.09.90005	Amplas Rol-#100	5,000.00	CM		
		30	E.09.90008	Amplas Rol-#320	10,000.00	CM		

Laporan Status Permintaan Barang (PB)

Status Permintaan Barang
Tanggal 01/01/2013 s/d 04/07/2016

Halaman 1

Permintaan Barang		Srl	Barang				Permintaan Pembelian			Bon Pengambilan Material		
Nomor	Tanggal		Kode	Nama / Spesifikasi	Sat	Jumlah	Nomor	Tanggal	Jumlah	Nomor	Tanggal	Jumlah
PB/2013/01/00001	05/01/2013		1	E.03.30052 Saklar / Seri isi 3 Panasonic	SET	10.00	PP/2013/01/00001	06/01/2013	5.00	BPM/2013/01/00001	20/01/2013	2.00
PB/2013/01/00002	10/01/2013		1	E.03.30052 Saklar / Seri isi 3 Panasonic	SET	50.00	PP/2013/01/00002	12/01/2013	50.00	BPM/2013/01/00002	21/01/2013	2.00
PB/2015/06/00001	03/06/2015		1	B.06.60034 Timber Mixing 2T x20L(150-190)P	CBM	10.00	PP/2015/06/00001	08/06/2015	10.00	BPM/2015/06/00001	12/06/2015	10.00
			2	B.06.60045 Plywood 15mm	Lbr	250.00	PP/2015/06/00001	08/06/2015	250.00	BPM/2015/06/00001	12/06/2015	250.00
			3	B.09.90006 Katalis Norox MEKP 9H	KG	16.00	PP/2015/06/00001	08/06/2015	16.00	BPM/2015/06/00001	12/06/2015	16.00
			4	B.09.90010 Silica Sand	Kg	740.00	PP/2015/06/00001	08/06/2015	740.00			
			5	D.01.10002 Tree L	Pes	1,000.00	PP/2015/06/00001	08/06/2015	1,000.00			
			6	D.01.10004 Tree S	Pes	1,000.00	PP/2015/06/00001	08/06/2015	1,000.00			
			7	B.09.90023 Resin XPR 0904 F	KG	240.00	PP/2015/06/00001	08/06/2015	240.00			
			8	B.08.80011 Box Wrap J 18 - 1205x900x89mm	Pes	1,000.00	PP/2015/06/00001	08/06/2015	1,000.00			
			9	B.08.80016 Kertas Minyak	Lbr	2,000.00	PP/2015/06/00001	08/06/2015	2,000.00			
			10	B.10.10009 Bolt KN M8x60x1.25	Pes	5,000.00	PP/2015/06/00001	08/06/2015	5,000.00			
			11	B.10.10022 EyeBolt NK #8	Pes	8,000.00	PP/2015/06/00001	08/06/2015	8,000.00			
			12	B.10.10032 Nails F20 / 1 Box = 5000 Pes	Pes	15,000.00	PP/2015/06/00001	08/06/2015	15,000.00			
			13	B.10.10033 Nails F25 / 1 Box = 5000 Pes	Pes	40,000.00	PP/2015/06/00001	08/06/2015	40,000.00			
			14	B.10.10035 Nanas E 11-M 8x13Tmm	Pes	2,000.00	PP/2015/06/00001	08/06/2015	2,000.00			
			15	B.10.10036 Nanas E 25-M 8x25Tmm	Pes	4,000.00	PP/2015/06/00001	08/06/2015	4,000.00			
			16	B.10.10045 SS AS 304-10m Dx6m P / 1lonjor jd 50 bty (1 lonjor di bagi 12cm)	Pes	2,000.00	PP/2015/06/00001	08/06/2015	2,000.00			
			17	B.10.10046 SS Pipa 201-1/2"Dx1.2Tmm / 1 lonjor jadi 85 pes (1 lonjor di bagi 7cm)	Pes	2,000.00	PP/2015/06/00001	08/06/2015	2,000.00			
			18	B.10.10062 Screw JP M8x31/4"	Pes	16,000.00	PP/2015/06/00001	08/06/2015	16,000.00			
			19	B.10.10068 Staples Gun ISI-1008J / 1 Pack = 5000 Pes	Pes	40,000.00	PP/2015/06/00001	08/06/2015	40,000.00			
			20	B.11.11014 PU Sanding Hardener ICN 21B	Ltr	76.00	PP/2015/06/00001	08/06/2015	76.00			
			21	B.11.11015 PU Sanding Sealer ICN 700A	Ltr	96.00	PP/2015/06/00001	08/06/2015	96.00			
			22	B.11.11016 PU TopCoat IGF 660A 70% Matt	Ltr	109.00	PP/2015/06/00001	08/06/2015	109.00			
			23	B.11.11018 PU Thinner R1280	Ltr	200.00	PP/2015/06/00001	08/06/2015	200.00			
			24	B.11.11028 Thinner Cuci AC-37	Ltr	30.00	PP/2015/06/00001	08/06/2015	30.00			
			25	B.11.11030 Wood Filler Mahony WS6113384	KG	100.00	PP/2015/06/00001	08/06/2015	100.00			
			26	E.01.10003 Desiccant 1000 gram	Pes	680.00	PP/2015/06/00001	08/06/2015	680.00			
			27	E.04.40003 Epoxy for Production	KG	20.00	PP/2015/06/00001	08/06/2015	20.00			
			28	E.04.40007 Lem Putih Rajawali / 1 pack = 800 GRM	GRM	135,000.00	PP/2015/06/00001	08/06/2015	35,000.00			

Laporan Bon Pengambilan Material (BPM)

Laporan Bon Permintaan Material											Halaman	1
Tanggal 01/01/2014 s/d 04/07/2016												
No. BPM		No. PB	Srl	Barang			Jumlah		Sisa	Keterangan		
Nomor	Tanggal			Kode	Nama / Spesifikasi	Sat	Diminta	Diterima				
BPM/2015/06/00001	12/06/2015	PB/2015/06/00001	1	B.06.60034	Timber Mixing 2Tx20L(150-190)P	CEM	10,00	10,00	0,00			
			2	B.06.60045	Plywood 15mm	Lbr	250,00	250,00	0,00			
			3	B.06.90006	Katalis Norox MEKP 9H	KG	16,00	0,00	16,00			

Laporan Status Bon Pengambilan Material (BPM)

Laporan Bon Permintaan Material											Halaman	1
Tanggal 01/01/2013 s/d 04/07/2016												
No. BPM		No. PB	Srl	Barang			Jumlah		Sisa	Keterangan		
Nomor	Tanggal			Kode	Nama / Spesifikasi	Sat	Diminta	Diterima				
BPM/2013/01/00001	20/01/2013	PB/2013/01/00001	1	E.03.30052	Saklar / Seri si 3 Panasonic	SET	2,00	2,00	0,00			
BPM/2013/01/00002	21/01/2013	PB/2013/01/00002	1	E.03.30052	Saklar / Seri si 3 Panasonic	SET	2,00	0,00	2,00			
BPM/2015/06/00001	12/06/2015	PB/2015/06/00001	1	B.06.60034	Timber Mixing 2Tx20L(150-190)P	CEM	10,00	10,00	0,00			
			2	B.06.60045	Plywood 15mm	Lbr	250,00	250,00	0,00			
			3	B.06.90006	Katalis Norox MEKP 9H	KG	16,00	0,00	16,00			

Purchase

Entry Purchase Order (PO)

Purchase Order

Month Juni 2015

PO. No. PO / 2015 / 06 / 00001

Date 09/Jun/2015 Cash Credit

Supplier A0040 Adhidaya Teknik

Detail

No.	Indent No.	Indent Item	Item Code	Description	Specification	UM Stored	Quantity	UM Purch	UM Conv	Quantity Purch	Price	Total
1	PP/2015/06/00001	1	B.06.60034	Timber Mixing 2Tx20L(150-190)P		CBM	10.00	CBM	1.0	10.00	1,800,000.00	18,000,000.00
2	PP/2015/06/00001	2	B.06.60045	Plywood 15mm		Lbr	250.00	Lbr	1.0	250.00	163,000.00	40,750,000.00
3	PP/2015/06/00001	3	B.09.90006	Kabels Norox MEKP 9H		KG	16.00	KG	1.0	16.00	46,330.38	741,286.08
*												

Payment Term Payment Termnya apa ???

Delivery Date Urgent

Note Catatan tambahan apa ????? ???? ?

Total 59,491,286.08

Discount 286.08

Tax 5,949,100.00

Total Net 65,440,100.00

Save
 Clear
 Delete
 Print
 Un-approve

Exit

Bila di-Click tombol *Print* maka akan tampil *Form PO* sbb,

 mdISentosa Pakis Pemada Asri A-16 Malang Telp. 081 369 297246		ORDER PEMBELIAN (OP)		Nomor : PO/2015/06/00001 Tanggal : 09/06/2015		
Kepada Yth : Adhidaya Teknik JI Pasar Baru Indah No 1						
<i>Sesuai dengan penawaran saudara, dengan ini mohon dikirim barang barang sbb,</i>						
No.	Kode	Nama dan Spesifikasi Barang	Satuan	Jumlah	Harga	
					Satuan	Jumlah
1	B.06.60034	Timber Mixing 2Tx20L(150-190)P	CBM	10	1,800,000.00	18,000,000.00
2	B.06.60045	Plywood 15mm	Ltr	250	163,000.00	40,750,000.00
3	B.09.90006	Katalis Norox MEKP 9H	KG	16	46,330.38	741,286.08
					Total	59,491,286.08
					Discount	286.08
					PPN	5,949,100.00
					Total Net	65,440,100.00
<u>Catatan.</u> Catatan tambahan apa ???? ????						
					Mengetahui Ka. Div. Prod. (.....)	

Daftar Purchase Order
Tanggal 01/01/2013 s/d 04/07/2016

Halaman 1

Order		Supplier	Srl	Barang				Jumlah	Nilai
No	Tanggal			Kode	Nama / Spesifikasi	Sat	Harga		
P O/2015.06/00001	09/06/2015	A0040 Adhidaya Teknik							
			1	B.06.60034	Timber Mixing 2Tx20L(150-190)P	CBM	1,800,000	10	18,000,000
			2	B.06.60045	Plywood 15mm	Lbr	163,000	250	40,750,000
			3	B.09.90006	Katalis Norox MEKP 9H	K G	46,330	16	741,286
								Total	59,491,286
								Grand Total	59,491,286

Laporan Status Purchase Order (PO)

Status Purchase Order
Tanggal 01/01/2013 s/d 04/07/2016

Halaman 1

Order		Supplier	Srl	Barang			Harga	Order		Terima		Sisa	
No	Tanggal			Kode	Nama / Spesifikasi	Sat		Jumlah	Nilai	Jumlah	Nilai	Jumlah	Nilai
P O/2015.06/00001	09/06/2015	A0040 Adhidaya Teknik											
			1	B.06.60034	Timber Mixing 2Tx20L(150-190)P	CBM	1,800,000	10	18,000,000	10	18,000,000	0	0
			2	B.06.60045	Plywood 15mm	Lbr	163,000	250	40,750,000	250	40,750,000	0	0
			3	B.09.90006	Katalis Norox MEKP 9H	K G	46,330	16	741,286	0	0	16	741,286
								Total	59,491,286	58,750,000	58,750,000	741,286	
								Grand Total	59,491,286	58,750,000	741,286		

Store (Gudang)

Entry Penerimaan Pembelian Barang

Penerimaan Pembelian Barang

Bulan Juni 2015

No. Transaksi LPB / 2015 / 06 / 00001

Tanggal 15/Jun/2015

Supplier A0040 Adhidaya Teknik

No. Bukti Bukti 1

Detail

No.	No. PO	Item PO	Kode Barang	Nama Barang	Spesifikasi	Sat. Beli	Qty beli	Harga Satuan	Total	Konv. Sat.	Sat. Pakai	Quantity
1	PO/2015/06/00001	1	B.06.60034	Timber Mixing 2Tx20L(150-15		CBM	10.00	1,800,000.00	18,000,000.00	1.0	CBM	10.00
2	PO/2015/06/00001	2	B.06.60045	Plywood 15mm		Lbr	250.00	163,000.00	40,750,000.00	1.0	Lbr	250.00
*												

Total	58,750,000.00
Discount	0
Tax	0
Total Net	58,750,000.00

Save
 Clear
 Delete
 Print
 Exit

Entry Pengeluaran/Pemakaian Barang

Pengeluaran Barang / Material

Bulan Juni 2015

No. Transaksi BAB / 2015 / 06 / 00001

Tanggal 15/Jun/2015 No. SPK SPK/2015/00001

No. BPM BPM/2015/06/00001

Detail

No.	Item BPM	Kode Barang	Nama Barang	Spesifikasi	Satuan	Jumlah
1	1	B.06.60034	Timber Mixing 2Tx20L(150-190)P		CBM	10.00
2	2	B.06.60045	Plywood 15mm		Lbr	50.00
3	2	B.06.60045	Plywood 15mm		Lbr	200.00
*						

Save
 Clear
 Delete
 Print
 Exit

Laporan Penerimaan Pembelian Barang

Transaksi Penerimaan Pembelian Barang

Halaman 1

Tanggal 01/01/2013 s/d 07/04/2016

No. Transaksi	Tanggal	Supplier	Kode Barang	Nama Barang & Spesifikasi	Jumlah Barang	Harga Satuan	Nilai
		Purchase Order					
LPB/2015/06/00001	15/06/2015	A0040 / Adhidaya Teknik					
		PO/2015/06/00001	B.06.60034	Timber Mixing 2Tx20L(150-190)P	10.00 CBM	1,800,000	18,000,000
		PO/2015/06/00001	B.06.60045	Plywood 15mm	280.00 Lbr	163,000	40,750,000
				Total			58,750,000
				Grand Total			58,750,000

Laporan Pengeluaran/Pemakaian Barang

Halaman 1

Transaksi Pemakaian Barang

Tanggal 01/01/2013 s/d 07/04/2016

No. BPM	No. SPK	No. Transaksi	Tanggal	Kode Barang	Nama Barang & Spesifikasi	Jumlah Barang
BPM/2013/01/00001		BAB/2013/01/00001	06/01/2013	E.03.30052	Saklar Seri isi 3 Panasonic	2.00 SET
BPM/2015/06/00001	SPK/2015/00001	BAB/2015/06/00001	15/06/2015	B.06.60034	Timber Mixing 2Tx20L(150-190)P	10.00 CBM
				B.06.60045	Plywood 15mm	50.00 Lbr
				B.06.60045	Plywood 15mm	200.00 Lbr

Kartu Stock

Kartu Stock
Per Tanggal 07/04/2016

Kode Barang A.01.10019
Nama Barang Java Mini - S
Spesifikasi
Satuan Pcs

Tanggal	Pemasukan/ Penerimaan	Pemakaian	Retur Pembelian	Retur Pemakaian	Adjustment	Stock
				<i>Stock Awal</i>		243.00
25/01/2013	0.00	200.00	0.00	0.00	0.00	43.00

Dicetak Tanggal 07/04/2016 Jam : 14:20:35

Stock Opname

Laporan Stock Opname
Per Tanggal 30/06/2015

Halaman 23

Kode	Nama Barang / Spesifikasi	Sat.	Penerimaan			Jumlah				Stock Akhir			
			Tanggal	Nomor	Jumlah	Femakaian	Retur Beli	Retur Pakai	Adjustment	Jumlah	Harga	Nilai	
B RAW MATERIAL													
B 06 Panel													
B 06 60020	Ham ster Wheel	Pes	01/01/2013	OB 2013/01/00001	5.00	0.00	0.00	0.00	0.00	0.00	5.00	0.00	0.00
B 06 60021	Stik Ice I (Coklat)	Pes	01/01/2013	OB 2013/01/00001	1,046.00	0.00	0.00	0.00	0.00	0.00	1,046.00	0.00	0.00
B 06 60022	Stik Ice I (Putih)	Pes	01/01/2013	OB 2013/01/00001	1,000.00	0.00	0.00	0.00	0.00	0.00	1,000.00	0.00	0.00
B 06 60023	Sendok Magnum	Pes	01/01/2013	OB 2013/01/00001	13,842.00	0.00	0.00	0.00	0.00	0.00	13,842.00	20.00	276,840.00
B 06 60024	Shell Clam p	Kg	01/01/2013	OB 2013/01/00001	141.35	0.00	0.00	0.00	0.00	0.00	141.35	9,500.00	1,342,825.00
B 06 60025	Shell Scallop L	Kg	01/01/2013	OB 2013/01/00001	186.18	0.00	0.00	0.00	0.00	0.00	186.18	7,500.00	1,396,349.95
B 06 60026	Shell Scallop S	Kg	01/01/2013	OB 2013/01/00001	113.15	0.00	0.00	0.00	0.00	0.00	113.15	7,500.00	848,625.01
B 06 60027	Sayur L	Pes	01/01/2013	OB 2013/01/00001	4,626.00	0.00	0.00	0.00	0.00	0.00	4,626.00	3,500.00	16,191,000.00
B 06 60028	Sayur M	Pes	01/01/2013	OB 2013/01/00001	6,005.00	0.00	0.00	0.00	0.00	0.00	6,005.00	3,500.00	21,017,500.00
B 06 60029	Sayur S	Pes	01/01/2013	OB 2013/01/00001	0.00	0.00	0.00	0.00	0.00	0.00	0.00	3,500.00	0.00
B 06 60030	Timber Mixing 2Tx10L(150-190)P	Cb	01/01/2013	OB 2013/01/00001	0.06	0.00	0.00	0.00	0.00	0.00	0.06	1,800,000.00	108,000.00
B 06 60031	Timber Mixing 2Tx10L(200-250)P	CB	01/01/2013	OB 2013/01/00001	0.65	0.00	0.00	0.00	0.00	0.00	0.65	2,200,000.00	1,429,999.95
B 06 60032	Timber Mixing 2Tx10L(80-140)P	CB	01/01/2013	OB 2013/01/00001	0.39	0.00	0.00	0.00	0.00	0.00	0.39	1,500,000.00	584,999.98
B 06 60033	Timber Mixing 2Tx20L(100-140)P	CB	01/01/2013	OB 2013/01/00001	0.00	0.00	0.00	0.00	0.00	0.00	0.00	2,200,000.00	0.00
B 06 60034	Timber Mixing 2Tx20L(150-190)P	CB	01/01/2013	OB 2013/01/00001	0.00	0.00	0.00	0.00	0.00	0.00	0.00	1,800,000.00	0.00
			15/06/2015	LP B 2015/06/00001	10.00	10.00	0.00	0.00	0.00	0.00	0.00	1,800,000.00	0.40
			Total/		10.00	10.00	0.00	0.00	0.00	0.00			0.40
B 06 60035	Timber Mixing 2Tx20L(200-250)P	CB	01/01/2013	OB 2013/01/00001	1.11	0.00	0.00	0.00	0.00	0.00	1.11	2,200,000.00	2,435,999.99
B 06 60036	Timber Mixing 2Tx6,5L(90-250)P	Cb	01/01/2013	OB 2013/01/00001	0.76	0.00	0.00	0.00	0.00	0.00	0.76	1,100,000.00	835,999.99
B 06 60037	Timber 3Tx10-20L(100-250)P	Cb	01/01/2013	OB 2013/01/00001	1.61	0.00	0.00	0.00	0.00	0.00	1.61	2,200,000.00	3,531,000.04
B 06 60038	Tiram L	Kg	01/01/2013	OB 2013/01/00001	200.61	0.00	0.00	0.00	0.00	0.00	200.61	11,000.00	2,206,710.01
B 06 60039	Tiram M	Kg	01/01/2013	OB 2013/01/00001	167.49	0.00	0.00	0.00	0.00	0.00	167.49	11,000.00	1,842,390.06
B 06 60040	Tiram S	Kg	01/01/2013	OB 2013/01/00001	39.93	0.00	0.00	0.00	0.00	0.00	39.93	11,000.00	439,230.00
B 06 60041	MDF 12mm	Lbr	01/01/2013	OB 2013/01/00001	2.00	0.00	0.00	0.00	0.00	0.00	2.00	110,000.00	220,000.00

Accounting

Entry Jurnal Kas

Cash Journal

Period
Month **Januari** 2014

Journal No. **CA / 2014 / 01 / 00005**

Date **06/Jan/2014** Payment Receipt

Cash Account **1.1.01.001 [Petty Cash IDR]**

Description **Pembelian tk.wijaya,tk sederhana dan SPBU**

No. Referensi Currency **Rp.** Exchange Rate **Rp. 1.00**

Details

No.	Account No.	Account Name	Sub Account	Sub Ledger	Description	Debit	Credit
1	5.2.01.002	Fuel - Trucks & Motorcycle	alex		Bensin motor	7,000.00	0.00
2	2.1.01.001	Accounts Payable Local	W0004	LPB/2014/01/00003	Oli SAE 40	135,000.00	0.00
3	2.1.01.001	Accounts Payable Local	S0009	LPB/2014/01/00039	1 sack semen gresik	53,500.00	0.00
4	2.1.01.001	Accounts Payable Local	P0003	LPB/2014/01/00040	Buku tulis besar	90,000.00	0.00
5	5.2.01.011	Repair/Maintain- Fac Buildings			Perlengkapan pabrik	92,500.00	0.00
Total						378,000.00	0.00
Netto						378,000.00	

Bila di-Click tombol *Print* maka akan tampil *Form Cash Voucher* sbb,



mdlSentosa
Patis Permatas 2012-16 Malang
Telp. 081 255 281244

Cash Payment

Date : 06/01/2014 Account No. : 1.1.01.001 PettyCash IDR
 Transaction No. : CA/2014/01/00005 Reference :
 Description : Pembelian tk.wijaya,tk sederhana dan SPBU Currency : Rp. Exchange Rate : 1.00

No.	No. Acc	Account Name	Sub Acc	Sub Ledger	Description	Debit	Credit
1	5.2.01.002	Fuel - Trucks & Motorcycle	alex		Bensin motor	7,000.00	0.00
2	2.1.01.001	Accounts Payable Local	W0004	LPB/2014/01/00003	Oli SAE 40	135,000.00	0.00
3	2.1.01.001	Accounts Payable Local	S0009	LPB/2014/01/00039	1 sack semen gresik	53,500.00	0.00
4	2.1.01.001	Accounts Payable Local	P0003	LPB/2014/01/00040	Buku tulis besar	90,000.00	0.00
5	5.2.01.011	Repair/Maintain- Fac Buildings			Perlengkapan pabrik	92,500.00	0.00
Total						378,000.00	
Netto						378,000.00	

Amount in word :
THREE HUNDRED SEVENTY-EIGHT THOUSAND Rupiah

Paid by,

Approved by,

Received by,

(.....)

(.....)

(.....)

Entry Jurnal Bank

Bank Journal

Period
Month **April** 2014

Journal No. **BA / 2014 / 04 / 00010**

Date **03/Apr/2014** Payment Receipt

Account No. **1.1.02.001 [BCA Rp 1238]**

Description **Pembayaran Dunia Coating Industry** Cheque No. Due Date

Reference Currency **Rp.** Exchange Rate **Rp. 1.00**

Details

No.	Account No.	Account Name	Sub Account	Sub Ledger	Description	Debit	Credit
1	2.1.01.001	Accounts Payable Local	D0016	LPB/2014/03/00001	Pembayaran PO 28-02 Pembaelian top c	5,412,960.00	0.00
2	1.1.15.001	PPN In	D0001		PPN	541,296.00	0.00

Total 5,954,256.00 0.00
Netto 5,954,256.00

Save Clear Delete UnPost Print Exit

Bila di-Click tombol **Print** maka akan tampil **Form Bank Voucher** sbb,

 **mdSentosa**
Patis Permatasari - Malang
Telp. 0341 518 211248

Bank Payment

Date : 03/04/2014
Transaction No. : BA/2014/04/00010
Description : Pembayaran Dunia Coating Industry
Cheque No. : Due Date : Account No. : 1.1.02.001 BCA Rp 1238
Reference : Currency : Rp. Exchange Rate : 1.00

No.	No. Acc	Account Name	Sub Acc	Sub Ledger	Description	Debit	Credit
1	2.1.01.001	Accounts Payable Local	D0016	LPB/2014/03/00001	Pembayaran P O 28-02 Pembaelian top coat,sanding sealer,hardener	5,412,960.00	0.00
2	1.1.15.001	PPN In	D0001		PPN	541,296.00	0.00

Total 5,954,256.00
Netto 5,954,256.00

Amount in word :
FIVE MILLION NINE HUNDRED FIFTY-FOUR THOUSAND TWO HUNDRED FIFTY-SIX Rupiah

Created by, Approved by, Paid by,
(ERNA) (.....) (.....)

Entry Jurnal Piutang

Receivable Journal

Period
Month **April** 2014

Journal No. **AR / 2014 / 04 / 00002**

Date **03/Apr/2014**

Description **Penjualan Export**

Account No. **1.1.03.001 [Accounts Receivable export]**

Sub Account **C0001 Cool Parrot**

Reference **INV/2014/008** as Sub ledger

Currency **US\$** Exchange Rate Rp. **11,313.00**

Duration **30** day(s) Due Date **03/May/2014**

Details

No.	Account No.	Account Name	Sub Account	Sub Ledger	Description	Debit	Credit
1	4.1.03.001	Export sales			C0001 Cool Parrot	0.00	6,185.55

Total 0.00 6,185.55
Net 6,185.55

Save Clear Delete Print Exit

Bila di-Click tombol *Print* maka akan tampil *Form Piutang* sbb,

 **mdl Sentosa**
Pekis Permata April A-10 Malang
Telp. 081 559 297240

JURNAL PIUTANG

Tanggal : 03/04/2014
No. Voucher : AR/2014/04/00002
Keterangan : Penjualan Export
No. Referensi : INV/2014/008

No. Account: 1.1.03.001 Accounts Receivable export
Sub Account: C0001 Cool Parrot
Mata Uang: US\$ Nilai tukar Rp. 11,313.00
Durasi: 30 hari
Tgl. Jatuh tempo: 03/05/2014

No.	No.Account	Sub Account	Sub Ledger	Keterangan	Debit	Kredit
1	4.1.03.001			C0001 Cool Parrot		6,185.55

Terbilang : Enam ribu seratus delapan puluh lima rupiah lima puluh lima sen

Total 6,185.55
Netto 6,185.55

Accounting Disetujui oleh, Diketahui oleh, Keuangan Diterima oleh,

(.....) (.....) (.....) (.....) (.....)

Entry Jurnal Hutang

Payable Journal

Period
Month **April** 2014

Journal No. **AP / 2014 / 04 / 00020**

Date **21/Apr/2014**

Description **Hutang Pembelian Barang**

Account No. **2.1.01.001 [Accounts Payable Local]**

Sub Account **A0019 Artha Toko**

Reference **LPB/2014/04/00021** as Sub ledger

Currency **Rp.** Exchange Rate **Rp. 1.00**

Duration **0** day(s) Due Date **21/Apr/2014**

Details

No.	Account No.	Account Name	Sub Account	Sub Ledger	Description	Debit	Credit
1	1.1.09.007	Hardware - B10			Pembelian SS AS304-8mmDx6mP	83,000.00	0.00

Total **83,000.00** 0.00
Net **83,000.00**

Save Clear Delete Print Exit

Bila di-Click tombol *Print* maka akan tampil *Form Hutang* sbb,

 **mdSentosa**
Patis Permatas & SIA-1K Malang
Telp. +62 31 58 281244

JURNAL HUTANG

Tanggal : 21/04/2014
No. Voucher : AP/2014/04/00020
Keterangan : Hutang Pembelian Barang
No. Referensi : LPB/2014/04/00021

No. Account : 2.1.01.001 Accounts Payable Local
Sub Account : A0019 Artha Toko
Mata Uang : Rp. Nilai tukar Rp. 1.00
Durasi : 0 hari
Tgl. Jatuh tempo : 21/04/2014

Uraian

No.	No. Account	Sub Account	Sub Ledger	Keterangan	Debit	Kredit
1	1.1.09.007			Pembelian SS AS304-8mmDx6mP	83,000.00	

Terbilang : *Delapan puluh tiga ribu rupiah*

Total **83,000.00**
Netto **83,000.00**

Accounting Disetujui oleh, Diketahui oleh, Keuangan Diterima oleh,

(.....) (.....) (.....) (.....) (.....)

Laporan Jurnal Kas

CASH JOURNAL
 Period : 01/01/2014 to 31/01/2014

Journal No.	Date	Reference	Description	Amount (Rp.)		Exchange Rate	Amount (Rp.)		Acc. No.	Sub. Acc	User
				Debit	Credit		Debit	Credit			
1.1.01.001 Petty Cash IDR											
CA/2014/01/00001	03/01/2014		Pembayaran PTPN XII Malangsa		70,000,000.00	1.00	70,000,000.00		1.1.01.001		ERNA
			Penetapan No.52/AJ/176/FAK/2013 Kebun Malangsa	70,000,000.00		1.00	70,000,000.00		1.1.13.003	P0001	
			Total per Jurnal	70,000,000.00	70,000,000.00		70,000,000.00	70,000,000.00			
CA/2014/01/00002	03/01/2014		Pembelian BBM dan hardware		17,000.00	1.00	17,000.00		1.1.01.001		EVA
			Busi utk Stamper	10,000.00		1.00	10,000.00		5.2.01.012		
			BBM Alek	7,000.00		1.00	7,000.00		5.2.01.002	alex	
			Total per Jurnal	17,000.00	17,000.00		17,000.00	17,000.00			
CA/2014/01/00003	03/01/2014		UM dan BBM		1,712,000.00	1.00	1,712,000.00		1.1.01.001		EVA
			UM 5 Kary	220,000.00		1.00	220,000.00		1.1.13.003	S0003	
			UM 2 Sopir	112,000.00		1.00	112,000.00		1.1.13.003	S0003	
			Solar N8239TE	850,000.00		1.00	850,000.00		1.1.13.003	S0003	
			Solar N8003TC	500,000.00		1.00	500,000.00		1.1.13.003	S0003	
			Supemisi 2 truck	10,000.00		1.00	10,000.00		1.1.13.003	S0003	
			Biaya Portal	20,000.00		1.00	20,000.00		1.1.13.003	S0003	
			Total per Jurnal	1,712,000.00	1,712,000.00		1,712,000.00	1,712,000.00			
CA/2014/01/00004	04/01/2014		Biaya Patroli Polisi dan koram il		200,000.00	1.00	200,000.00		1.1.01.001		EVA
			Uang Patroli	200,000.00		1.00	200,000.00		5.5.05.002	01	
			Total per Jurnal	200,000.00	200,000.00		200,000.00	200,000.00			
CA/2014/01/00005	06/01/2014		Pembelian tk.wijaya,tk sederhana dan SPBU		378,000.00	1.00	378,000.00		1.1.01.001		EVA
			Bensin motor	7,000.00		1.00	7,000.00		5.2.01.002	alex	
			oli SAE 40	135,000.00		1.00	135,000.00		2.1.01.001	W0004	
			1 sack semen gresik	53,500.00		1.00	53,500.00		2.1.01.001	S0009	
			Buku tulis besar	90,000.00		1.00	90,000.00		2.1.01.001	P0003	
			Perengkapan pabrik	92,500.00		1.00	92,500.00		5.2.01.011		
			Total per Jurnal	378,000.00	378,000.00		378,000.00	378,000.00			
CA/2014/01/00006	07/01/2014		Pembelian Tk. Yap Electric		93,000.00	1.00	93,000.00		1.1.01.001		EVA
			5 setting lampu	75,000.00		1.00	75,000.00		5.2.01.011		
			6 m kabel 1mm	18,000.00		1.00	18,000.00		5.2.01.011		
			Total per Jurnal	93,000.00	93,000.00		93,000.00	93,000.00			
CA/2014/01/00007	10/01/2014		Pembelian tk Aneka jaya dan SPBU		43,000.00	1.00	43,000.00		1.1.01.001		EVA
			Bensin motor	7,000.00		1.00	7,000.00		5.2.01.002	alex	

Laporan Jurnal Bank

BANK JOURNAL
 Period : 01/01/2014 to 31/01/2014

Journal No.	Date	Cheque No. Reference	Description	Amount (US\$)		Exchange Rate	Amount (Rp.)		Acc. No.	Sub. Acc	User
				Debit	Credit		Debit	Credit			
1.1.02.001 BCA Rp 1238											
BA/2014/01/00041	08/01/2014		Penerimaan Piutang Skywet	3,995.00		12,100.00	48,339,500.00		1.1.02.001		ERNA
			INV/2014/0001		4,000.00	12,100.00		48,400,000.00	1.1.03.001	S0001	
			Bank charge	5.00		12,100.00	60,500.00		5.5.05.028		
			Total per Jurnal	4,000.00	4,000.00		48,400,000.00	48,400,000.00			
BA/2014/01/00042	15/01/2014		Penerimaan Piutang Skywet	754.25		11,925.00	8,994,431.25		1.1.02.001		ERNA
			Invoice 2013-021		759.25	11,925.00		9,054,056.25	1.1.03.001	S0001	
			Bank charge	5.00		11,925.00	59,625.00		5.5.05.028		
			Total per Jurnal	759.25	759.25		9,054,056.25	9,054,056.25			
BA/2014/01/00045	22/01/2014		Penerimaan Piutang Papagein	8,782.10		12,000.00	105,385,200.00		1.1.02.001		ERNA
			Invoice 2013-023		8,787.10	12,000.00		105,445,200.00	1.1.03.001	P0002	
			Bank charge	5.00		12,000.00	60,000.00		5.5.05.028		
			Total per Jurnal	8,787.10	8,787.10		105,445,200.00	105,445,200.00			
BA/2014/01/00046	24/01/2014		Penerimaan Piutang A & E	19,960.00		12,025.00	240,019,000.00		1.1.02.001		ERNA
			Pembayaran Inv 2013-024		19,965.00	12,025.00		240,079,125.00	1.1.03.001	A0001	
			Bank charge	5.00		12,025.00	60,125.00		5.5.05.028		
			Total per Jurnal	19,965.00	19,965.00		240,079,125.00	240,079,125.00			
BA/2014/01/00047	29/01/2014		Penerimaan Piutang Skywet	2,778.10		12,068.28	33,526,888.67		1.1.02.001		ERNA
			INV/2014/00001		2,783.10	12,068.28		33,587,230.07	1.1.03.001	S0001	
			Bank charge	5.00		12,068.28	60,341.40		5.5.05.028		
			Total per Jurnal	2,783.10	2,783.10		33,587,230.07	33,587,230.07			
			Grand Total	36,294.45	36,294.45		436,565,611.32	436,565,611.32			

Laporan General Ledger

mdSentosa

GENERAL LEDGER

Hal. 1

Date from 01/01/2014 to 31/01/2014

(Rp.)

Account No. 1.1.01.001

Account Name Petty Cash IDR

Date	Trx. No	Description	Acc. Lawan	Mutation		Balance
				Debit	Credit	
		Saldo awal				9,920,661.00 D
03/01/2014						
	BA/2014/01/00001	Untuk pembayaran PTPN XII Malang Sari	1.1.02.001	70,000,000.00	0.00	79,920,661.00 D
	BA/2014/01/00002	Petty cash rozzy	1.1.02.001	7,000,000.00	0.00	86,920,661.00 D
	CA/2014/01/00001	Penetapan No.52/AJ/2176/FAX/2013 Kebun Malang Sari	1.1.13.003	0.00	70,000,000.00	16,920,661.00 D
	CA/2014/01/00002	Busi utk Stam per BMW Alek	5.2.01.012 5.2.01.002	0.00 0.00	10,000.00 7,000.00	16,910,661.00 D 16,903,661.00 D
	CA/2014/01/00003	UM 5 Kary UM 2 Sopir Solar N8239TE Solar N8003TC Supervisi 2 truck Biaya Portal	1.1.13.003 1.1.13.003 1.1.13.003 1.1.13.003 1.1.13.003 1.1.13.003	0.00 0.00 0.00 0.00 0.00 0.00	220,000.00 112,000.00 850,000.00 500,000.00 10,000.00 20,000.00	16,683,661.00 D 16,571,661.00 D 15,721,661.00 D 15,221,661.00 D 15,211,661.00 D 15,191,661.00 D
	CA/2014/01/00035	Solar dan bensin utk genset	2.1.01.001	0.00	965,000.00	14,226,661.00 D
04/01/2014						
	CA/2014/01/00004	Uang Patroli	5.5.05.002	0.00	200,000.00	14,026,661.00 D
06/01/2014						
	CA/2014/01/00005	Bensin motor oli SAE 40 1 sack semen gresik Buku tulis besar Perlengkapan pabrik	5.2.01.002 2.1.01.001 2.1.01.001 2.1.01.001 5.2.01.011	0.00 0.00 0.00 0.00 0.00	7,000.00 135,000.00 53,500.00 90,000.00 92,500.00	14,019,661.00 D 13,884,661.00 D 13,831,161.00 D 13,741,161.00 D 13,648,661.00 D
07/01/2014						
	CA/2014/01/00006	5 set fitting lampu 6 m kabel 1mm	5.2.01.011 5.2.01.011	0.00 0.00	75,000.00 18,000.00	13,573,661.00 D 13,555,661.00 D
	CA/2014/01/00036	DP 50% Bandsaw Martin Miller	2.1.01.001	0.00	650,000.00	12,905,661.00 D
10/01/2014						
	CA/2014/01/00007	Bensin motor 6 pc cut disk 2 pc fitting guci	5.2.01.002 2.1.01.001 5.2.01.012	0.00 0.00 0.00	7,000.00 18,000.00 18,000.00	12,898,661.00 D 12,880,661.00 D 12,862,661.00 D
	CA/2014/01/00008	5 Kary Kebun 2 Sopir Kebun	1.1.13.003 1.1.13.003	0.00 0.00	220,000.00 112,000.00	12,642,661.00 D 12,530,661.00 D

Laporan Trial Balance

TRIAL BALANCE
January - 2014

Account No.	Account Name	Opening Balance		Mutation		Balance		Profit / Lost		Balance Sheet	
		Debit	Credit	Debit	Credit	Debit	Credit	Debit	Credit	Debit	Credit
1.1.1.1.1.1	Petty Cash B.R	8,229,241.00		8,229,241.00	0.00	8,229,241.00					8,229,241.00
1.1.1.1.1.2	Petty Cash USD										
1.1.1.1.1.3	BC S Rp 1212	24,244,249.25		24,244,249.25	48,247,249.25	24,244,249.25					24,244,249.25
1.1.1.1.1.4	BC S Rp 8442	45,124,249.25			24,249.25						45,124,249.25
1.1.1.1.1.5	BR Syariah Rp 5141										
1.1.1.1.1.6	Accounts Receivable export		22,374,249.25	22,374,249.25	48,247,249.25				48,247,249.25		48,247,249.25
1.1.1.1.1.7	Cadangan F erugah Piutang										
1.1.1.1.1.8	Piutang Pihak I edisi			4,249,249.25		4,249,249.25					4,249,249.25
1.1.1.1.1.9	Piutang K erjasama			8,249,249.25		8,249,249.25					8,249,249.25
1.1.1.1.1.10	Piutang Direksi										
1.1.1.1.1.11	Piutang Operasi	10,249,249.25				10,249,249.25					10,249,249.25
1.1.1.1.1.12	FG - 1 Trees	424,249,249.25		224,249,249.25	11,249,249.25	124,249,249.25					124,249,249.25
1.1.1.1.1.13	FG - 2 Branches	1,249,249.25		44,249,249.25	11,249,249.25	44,249,249.25					44,249,249.25
1.1.1.1.1.14	FG - 3 Toys	44,249,249.25		224,249,249.25	11,249,249.25	44,249,249.25					44,249,249.25
1.1.1.1.1.15	FG - 4 Cutters	44,249,249.25		44,249,249.25	24,249,249.25	44,249,249.25					44,249,249.25
1.1.1.1.1.16	FG - 5 Cabs	11,249,249.25				11,249,249.25					11,249,249.25
1.1.1.1.1.17	FG - 6 Cages	11,249,249.25				11,249,249.25					11,249,249.25
1.1.1.1.1.18	FG - 7 Toy Parts, Bull ed Pack										
1.1.1.1.1.19	FG - 8 HSCs	11,249,249.25				11,249,249.25					11,249,249.25
1.1.1.1.1.20	FG - 9 Samples	1,249,249.25				1,249,249.25					1,249,249.25
1.1.1.1.1.21	FG - 10	1,249,249.25				1,249,249.25					1,249,249.25
1.1.1.1.1.22	FG - 11										
1.1.1.1.1.23	Raw materials Wood - Others - Bx 1, Bx 2, Bx 3	1,249,249.25		1,249,249.25	48,249,249.25	1,249,249.25					1,249,249.25
1.1.1.1.1.24	Raw materials Wood E omponen -	1,249,249.25		48,249,249.25	1,249,249.25	48,249,249.25					48,249,249.25
1.1.1.1.1.25	Accessories - Bx 4	24,249,249.25			24,249,249.25	24,249,249.25					24,249,249.25
1.1.1.1.1.26	Tail - Bx 5	11,249,249.25			11,249,249.25	11,249,249.25					11,249,249.25
1.1.1.1.1.27	Panel - Bx 6	44,249,249.25		11,249,249.25	24,249,249.25	44,249,249.25					44,249,249.25
1.1.1.1.1.28	Flah - Bx 7	11,249,249.25			11,249,249.25	11,249,249.25					11,249,249.25
1.1.1.1.1.29	Packaging - Bx 8	11,249,249.25		44,249,249.25	11,249,249.25	44,249,249.25					44,249,249.25
1.1.1.1.1.30	Chemical - Bx 9	11,249,249.25			11,249,249.25	11,249,249.25					11,249,249.25
1.1.1.1.1.31	Hardware - B 10	11,249,249.25		44,249,249.25	11,249,249.25	44,249,249.25					44,249,249.25
1.1.1.1.1.32	Printing - B 11	11,249,249.25			11,249,249.25	11,249,249.25					11,249,249.25
1.1.1.1.1.33	Hangtag - C 1 - 12	11,249,249.25			11,249,249.25	11,249,249.25					11,249,249.25
1.1.1.1.1.34	Miscellaneous	11,249,249.25				11,249,249.25					11,249,249.25
1.1.1.1.1.35	B P		1,249,249.25	1,249,249.25	1,249,249.25				1,249,249.25		1,249,249.25
1.1.1.1.1.36	Persediaan BBI dan OLI - E 14	1,249,249.25		1,249,249.25	1,249,249.25	1,249,249.25					1,249,249.25
1.1.1.1.1.37	Persediaan sumber - E 15 - E 16	11,249,249.25				11,249,249.25					11,249,249.25